

CG 26

3D ASPECTS OF NATM TUNNELLING

Helmut F. Schweiger

Computational Geotechnics Group
Institute for Soil Mechanics and Foundation Engineering
Graz University of Technology

CONTENTS

- **Introduction**
- **Typical excavation sequence for NATM-tunnels**
- **Modelling 3D-effects in plane strain analysis**
- **Influence of small strain stiffness**
- **3D modelling**
- **Modelling of face stability problems**
- **Summary**

INTRODUCTION

■ 3-D Models

- **easy modelling of excavation sequence**
- **computational effort high**
- **essential for analysis of face stability**

■ Plane Strain

- **assumption of pre-relaxation factors**
- **excavation sequence in cross section**
- **face stability cannot be considered**
- **"state of the art" in practice**

TYPICAL NATM EXCAVATION

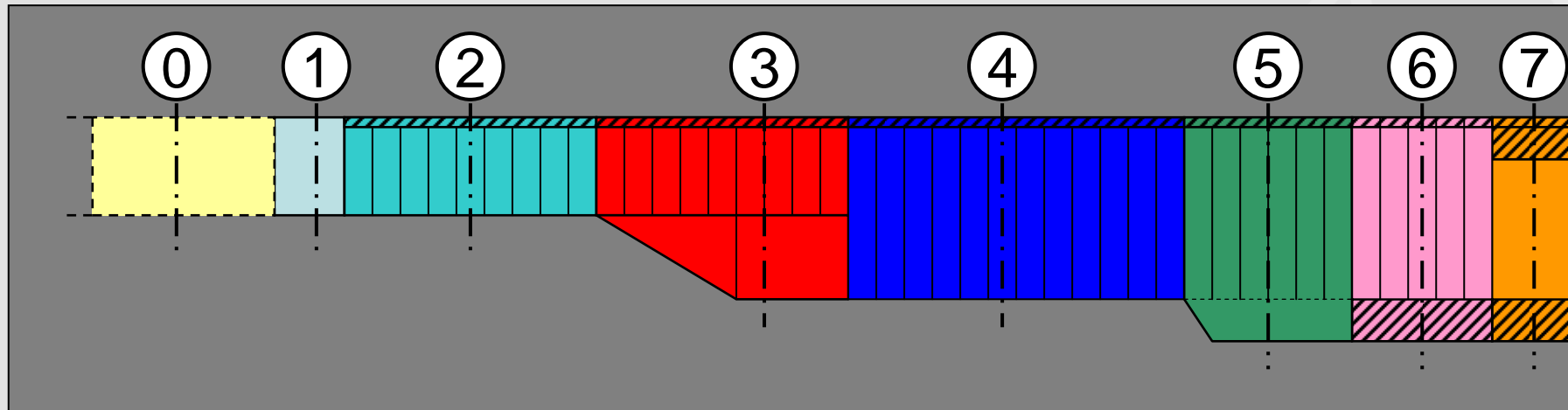

①

initial stress state

②

primary support
of top heading

④

primary support
of bench

⑥

tunnel invert

①

unsupported zone
at tunnel face

③

transition top head.
- bench excavation

⑤

transition bench –
invert excavation

⑦

final
lining

EXAMPLE OF STAGED EXCAVATION



DEFORMATION AHEAD OF FACE

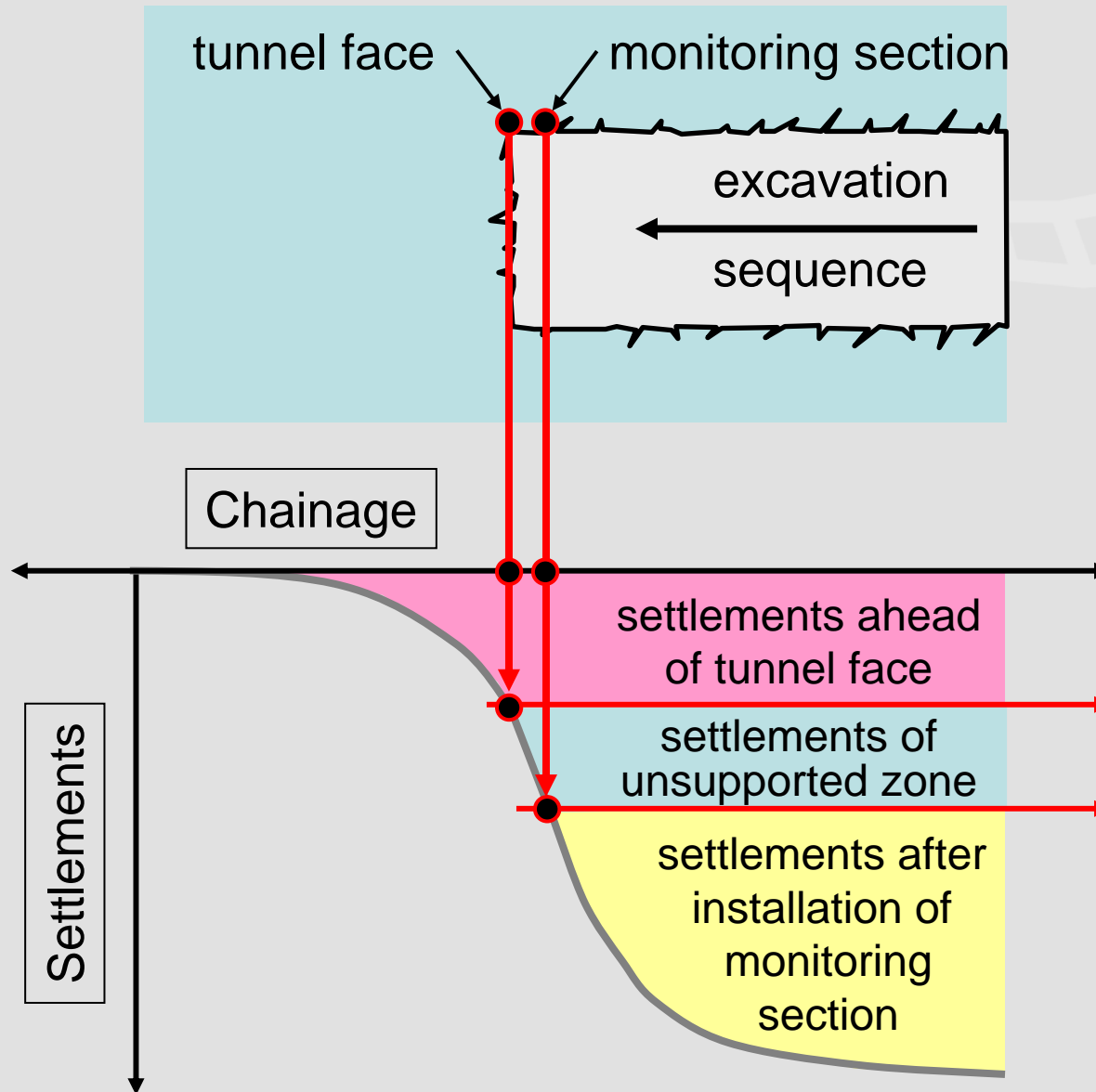

2D MODELLING - LOAD REDUCTION METHOD

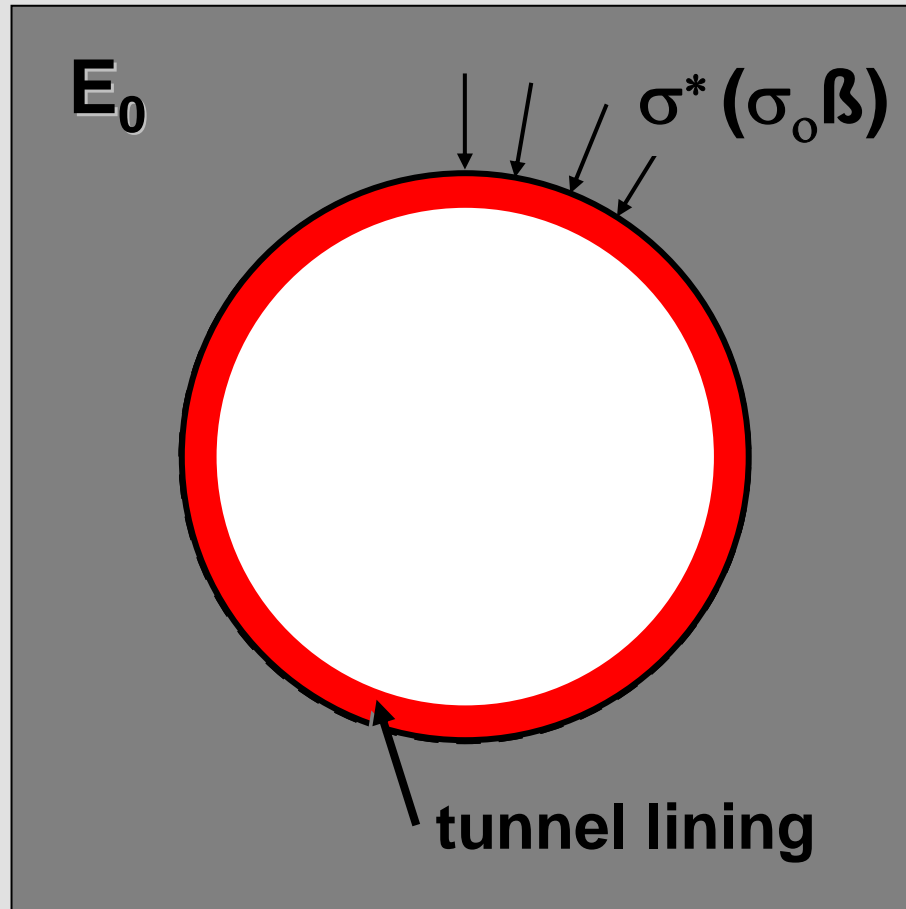

approximate
values for β :

$\beta = 0.2 - 0.5$
for top heading
excavation

$\beta = 0.4 - 0.8$
for side drift
excavation

(Laabmayr & Swoboda 1986)

PLAXIS: Mstage 1- β

2D MODELLING - STIFFNESS REDUCTION METHOD

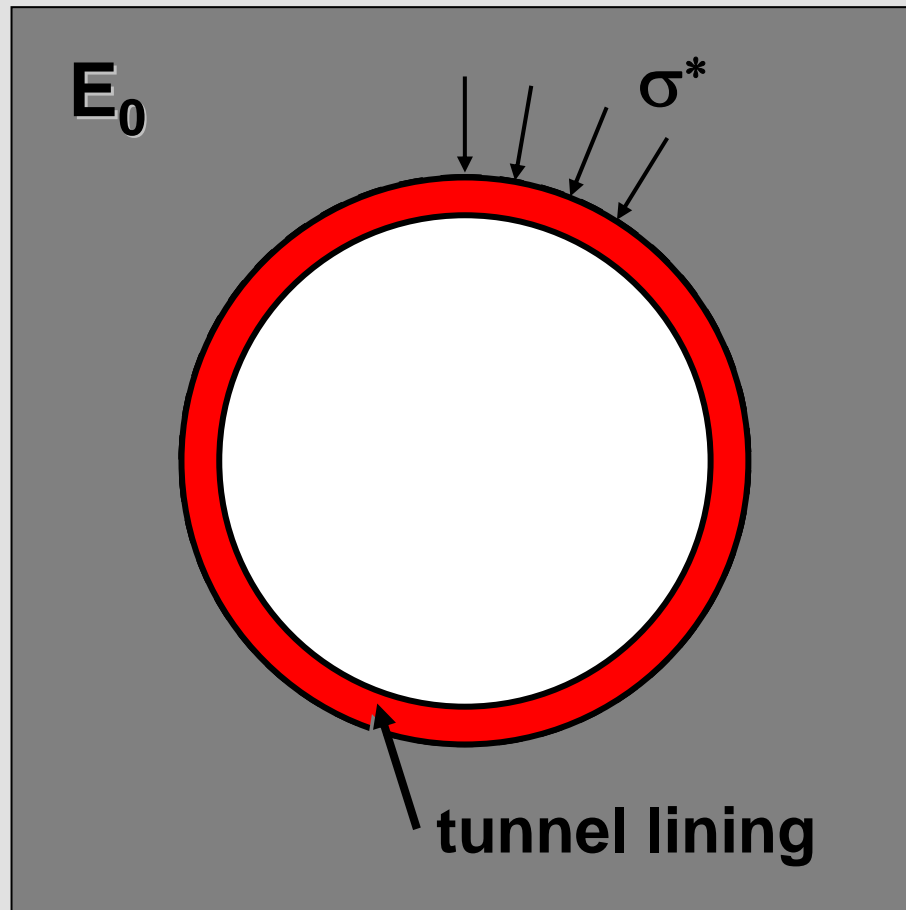

approximate
values for α :

$$\alpha = 0.3 - 0.5$$

(Schikora & Fink 1982)

PRE-RELAXATION

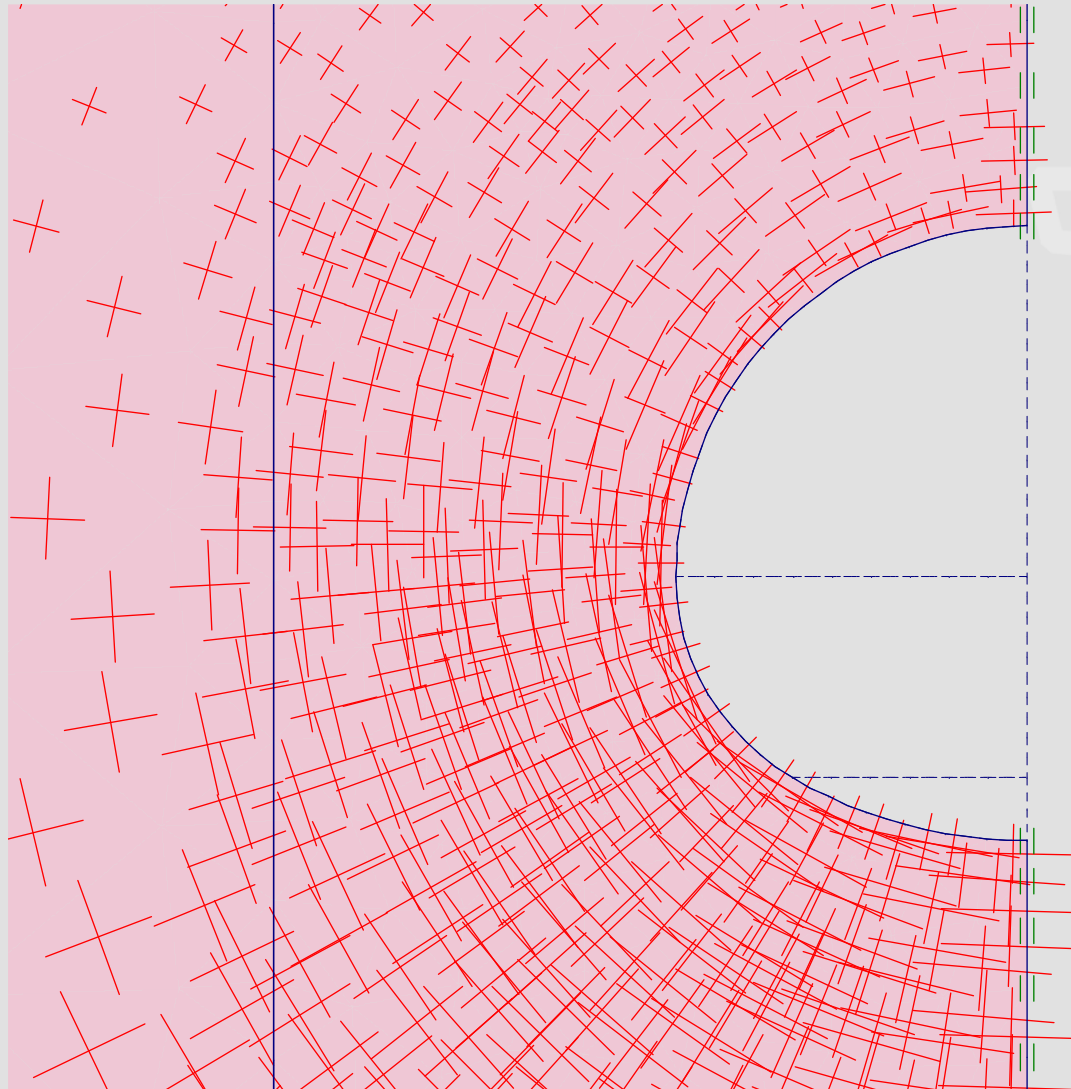

FULL EXCAVATION WITH LINING

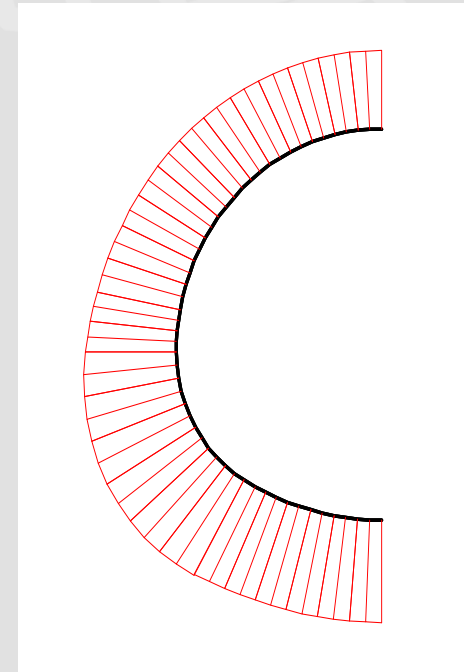
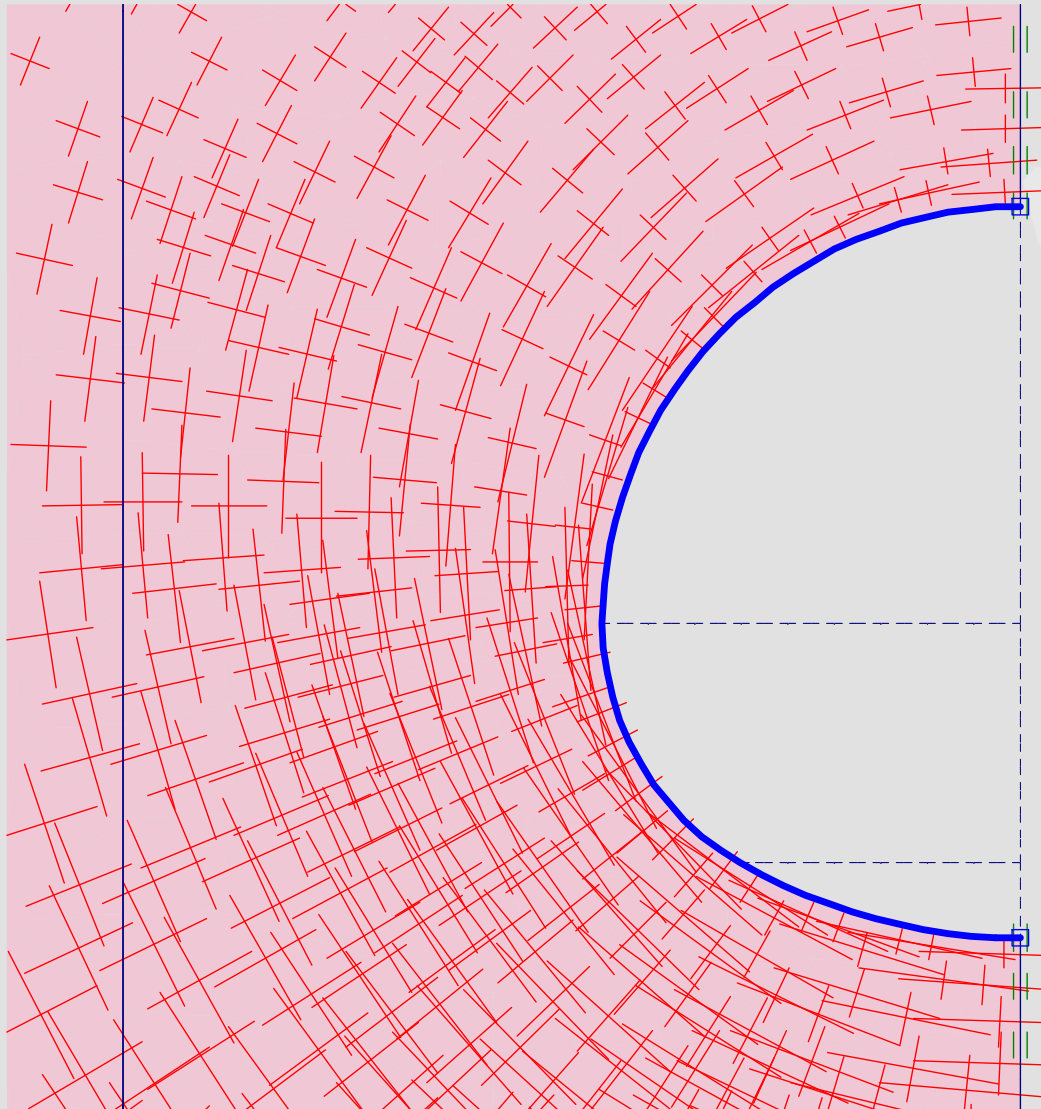

FULL EXCAVATION WITHOUT LINING

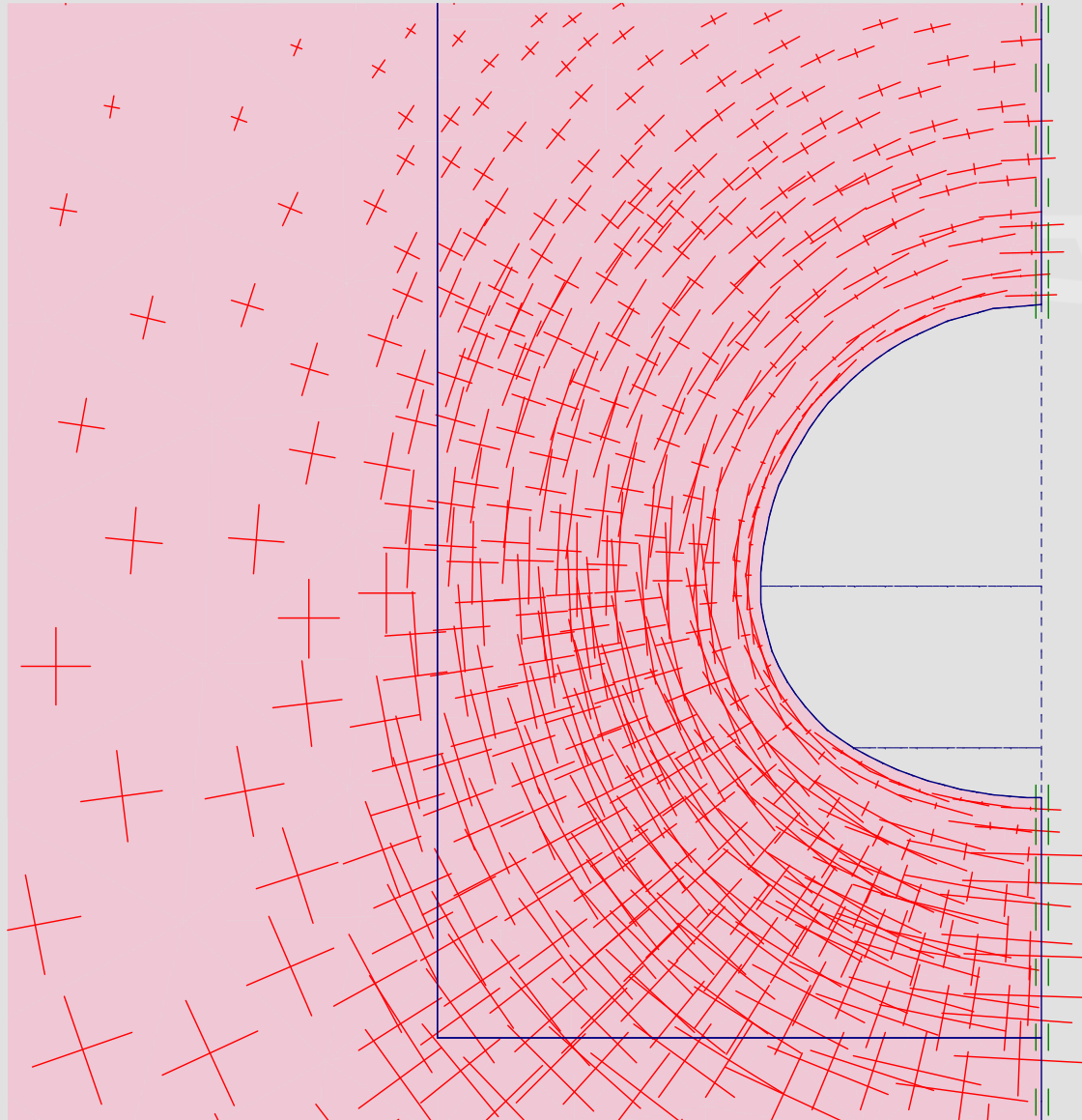

"PLASTIC ZONE" WITHOUT LINING

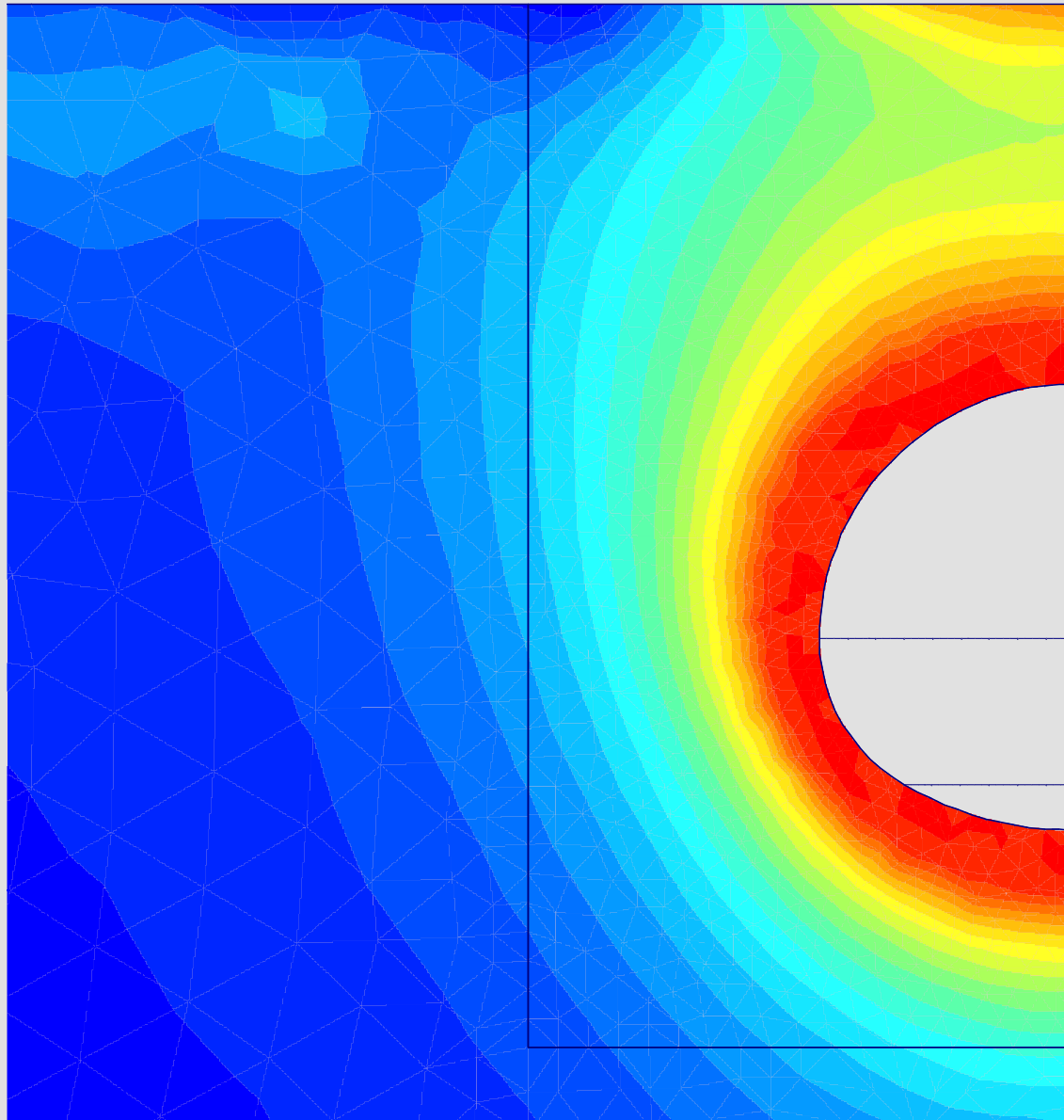

"PLASTIC ZONE" WITH LINING

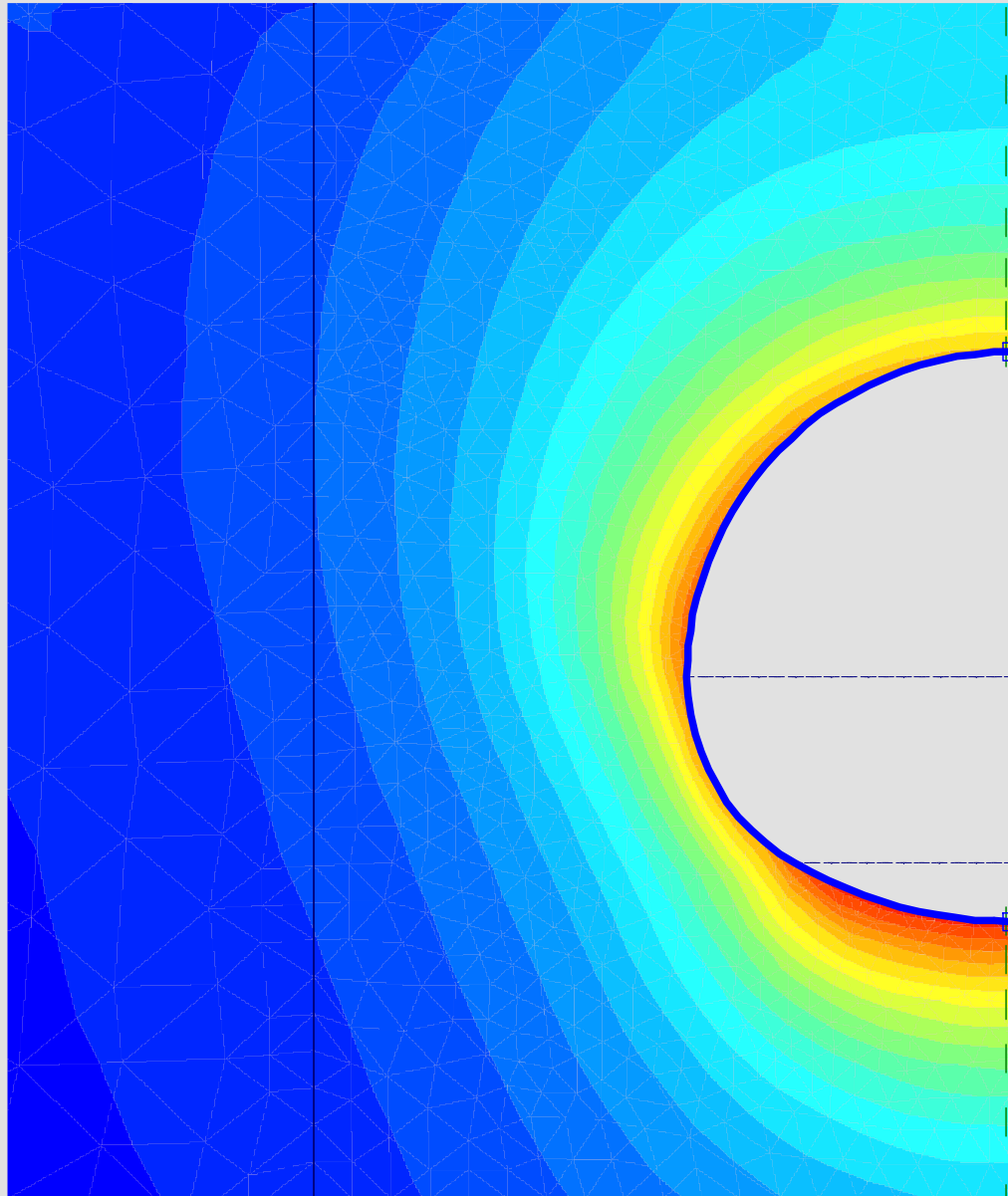

CHOICE OF α AND β

- values depend on:
 - ground conditions
 - length of unsupported section
 - advance rate
 - time of construction of invert
 - experience of personnel
 -

WHICH METHOD ?

- **Working Group 1.6 of DGGT**
 - > Load Reduction Method

- **Stiffness Reduction Method**
 - Influence of
 - Poisson ratio
 - Constitutive model

- **Correlation of α and β very difficult**
(Baumann & Hilber 1985, Schweiger et al. 1997)

MODELLING OF SUPPORT MEASURES

- **Shotcrete**
 - strength and stiffness highly time dependent
 - increase of Young's modulus for subsequent excavation steps is a practical approach
 - alternatively complex constitutive model can be used

- **Rock bolts**
 - in practice often by means of increase of cohesion
 - special elements of various types (bars, beams, ..)

- **Final concrete lining**
 - additional calculation without modelling of excavation sequence in detail (subgrade reaction method)
 - from FE-analysis assuming that shotcrete lining carries no load in the long term

SUPPORT TOP HEADING

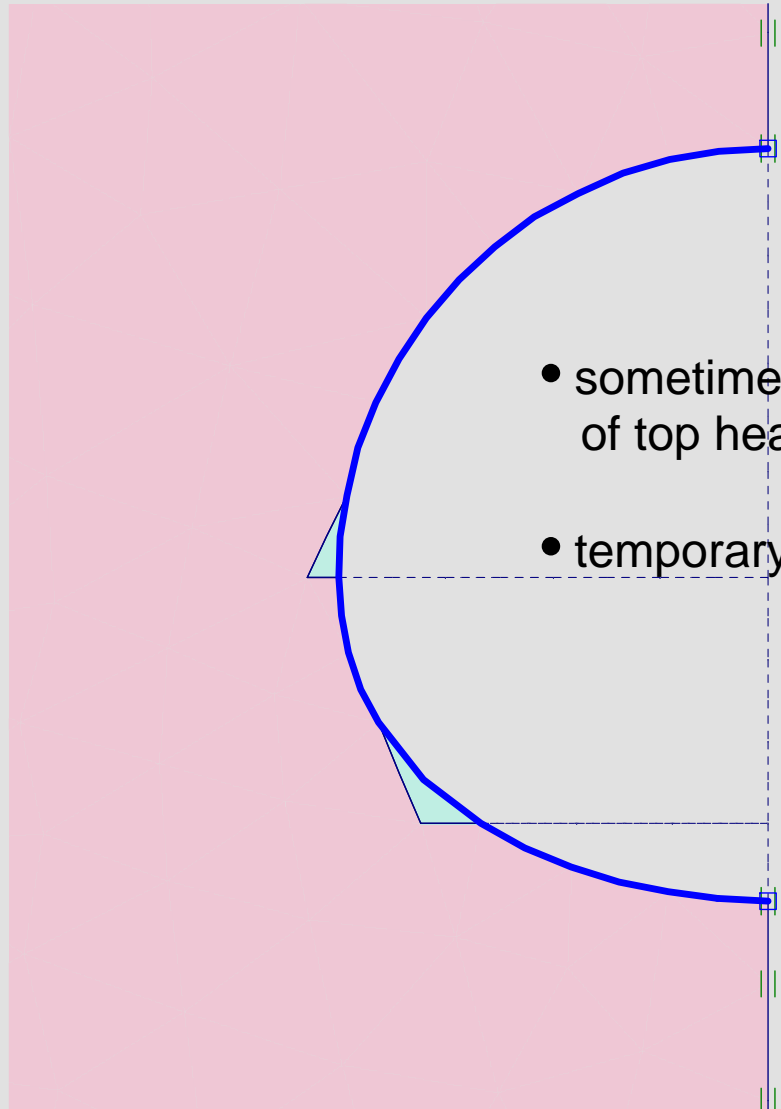

- sometimes not sufficient support for beam of top heading > numerical problems
- temporary invert for top heading

BOUNDARY CONDITIONS

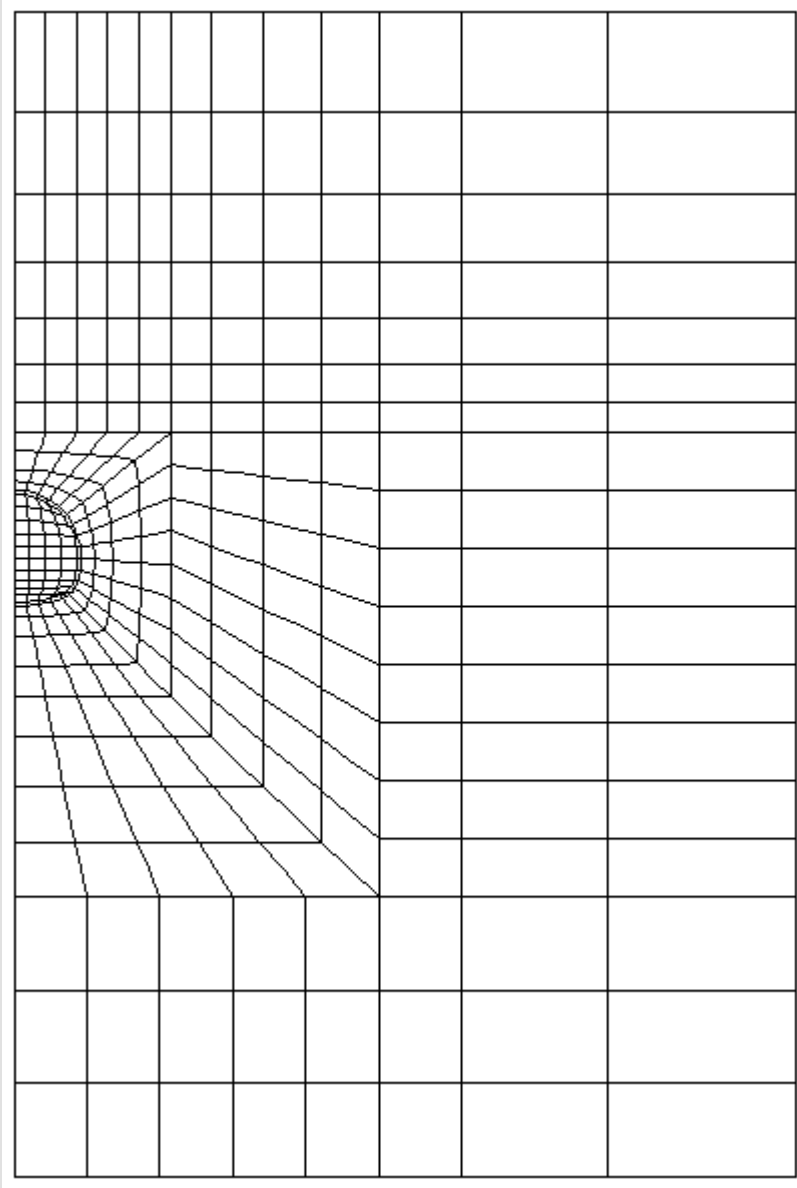

lateral: approx. 4 - 5 D

top: ground surface or
approx. 3 D

bottom: 2-3 D (geology !?)

**attention in rocks when
joints are present !**

EXAMPLE - INFLUENCE OF SMALL STRAIN STIFFNESS

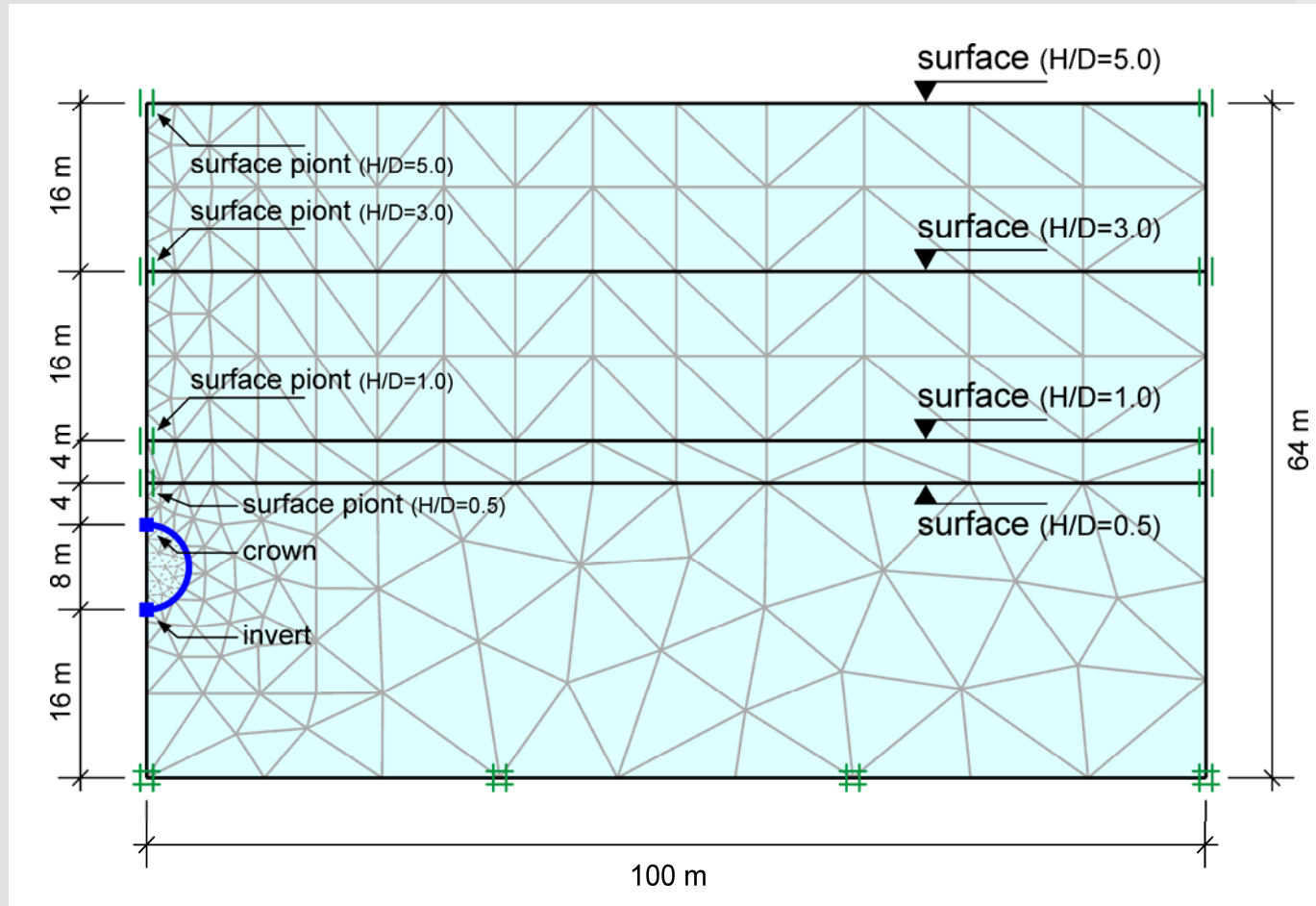

- Variation of overburden ($H/D=0.5, 1.0, 3.0, 5.0$)
- Increase of distance between tunnel and bottom boundary of the mesh to 4D
- Multilaminate Model for Soil, Mohr-Coulomb Model

SURFACE SETTLEMENTS

Mohr-Coulomb Model

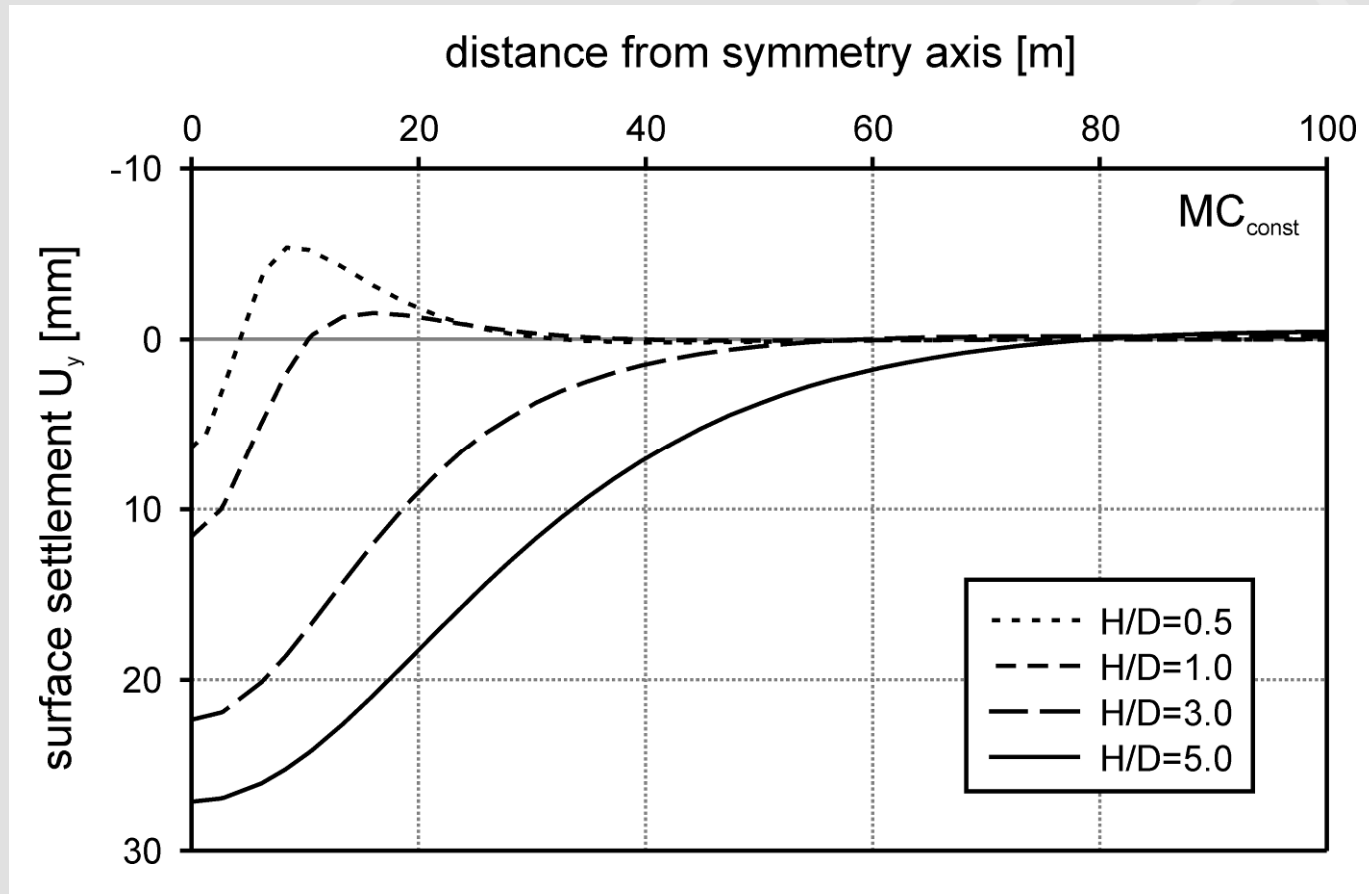

- Variation of overburden ($H/D=0.5, 1.0, 3.0, 5.0$)

SURFACE SETTLEMENTS

Multilaminate Model for Soil with small strain stiffness

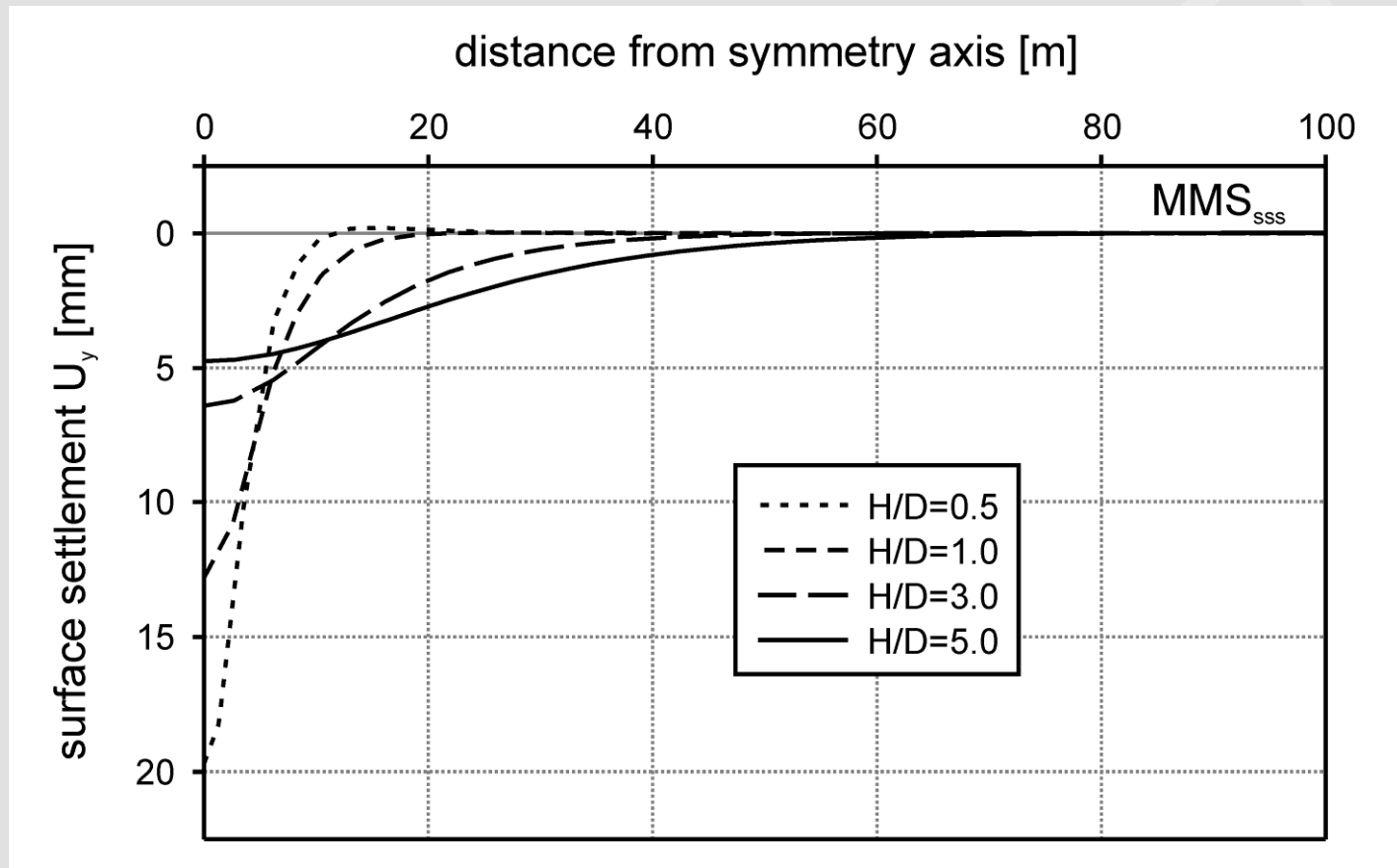

- Variation of overburden (H/D=0.5, 1.0, 3.0, 5.0)

SURFACE SETTLEMENTS

Mohr-Coulomb Model

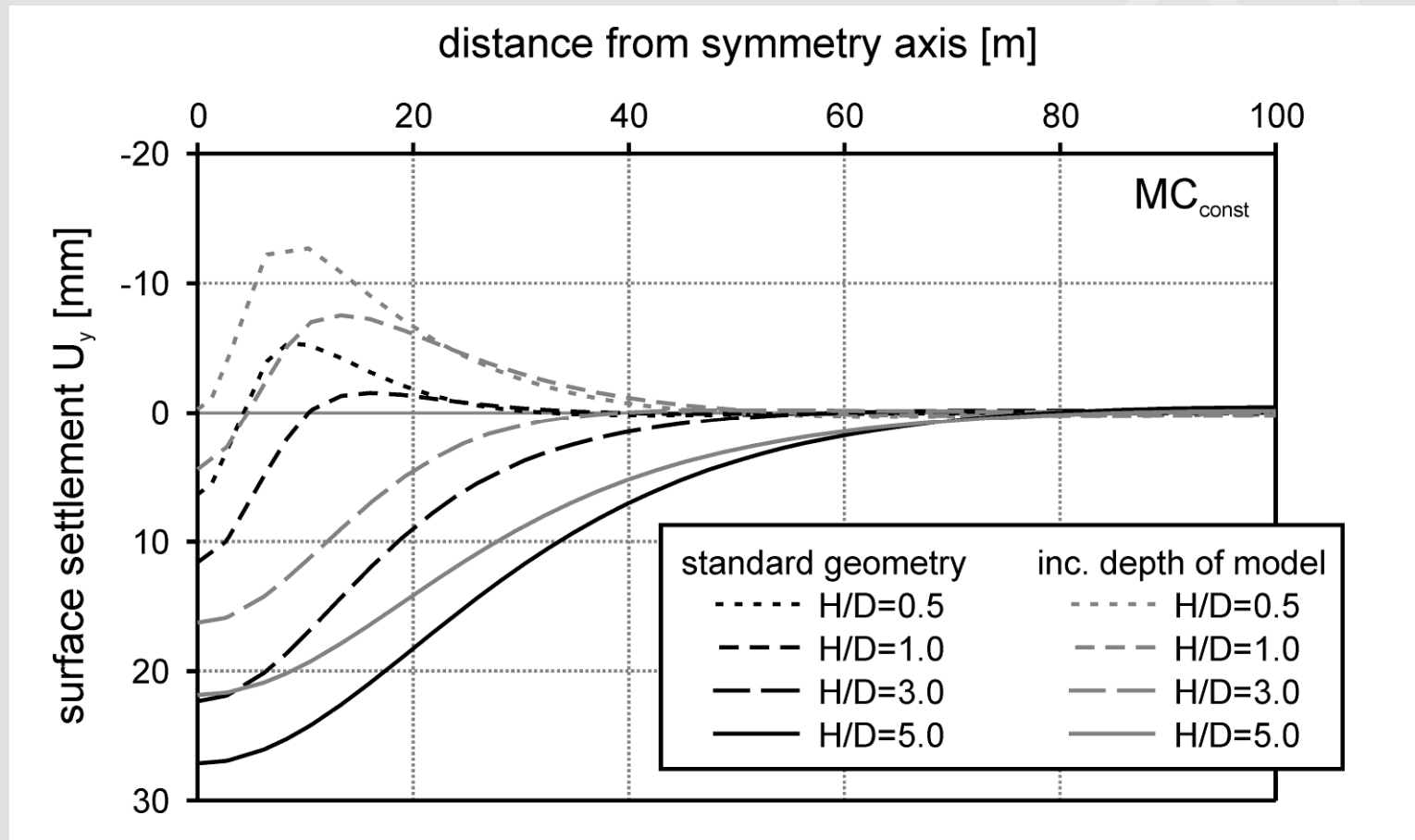

- Increase of distance between tunnel and bottom boundary of the mesh

SURFACE SETTLEMENTS

Multilaminate Model for Soil with small strain stiffness

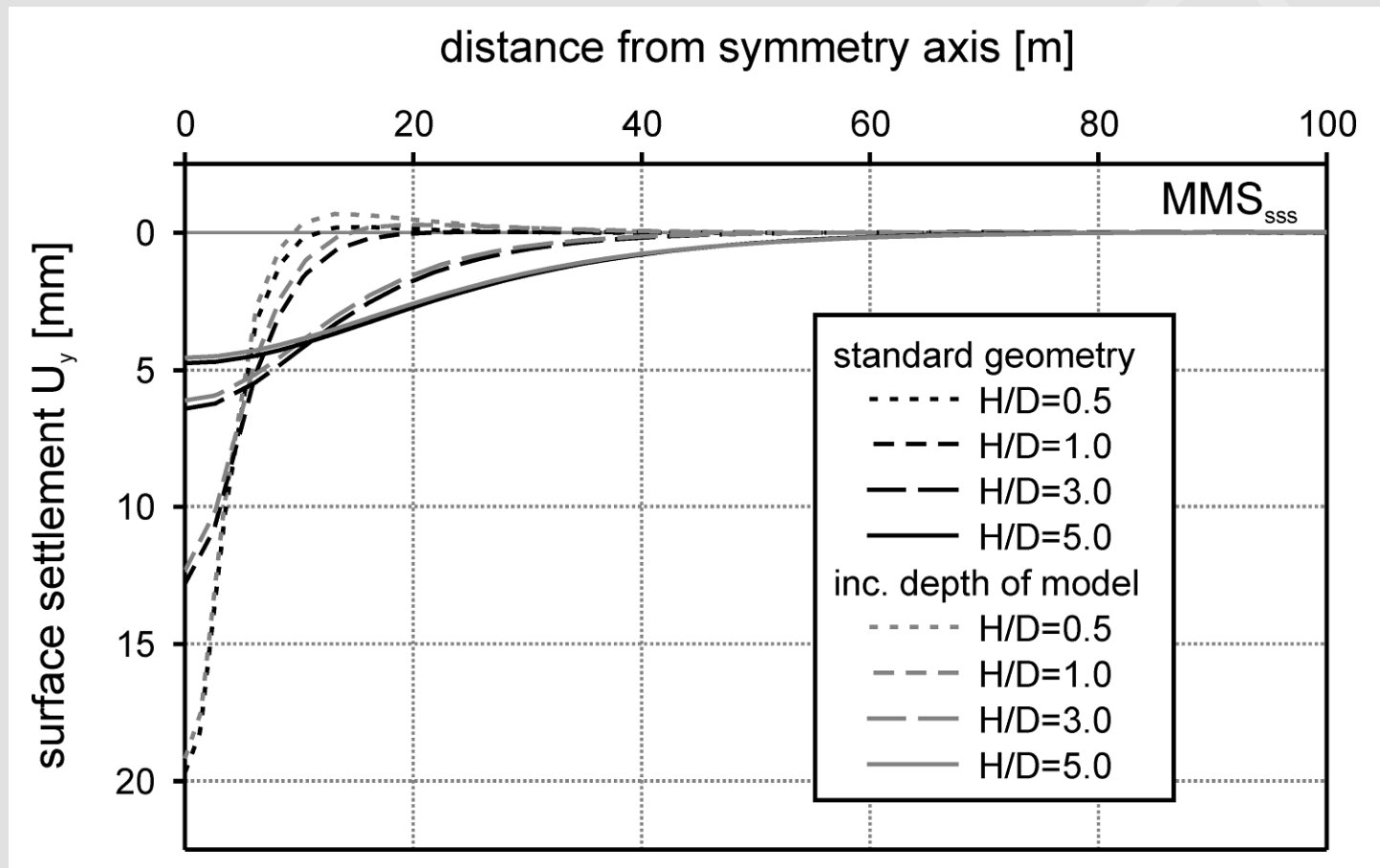

- Increase of distance between tunnel and bottom boundary of the mesh

COMPARISON OF NORMALISED SURFACE SETTLEMENTS

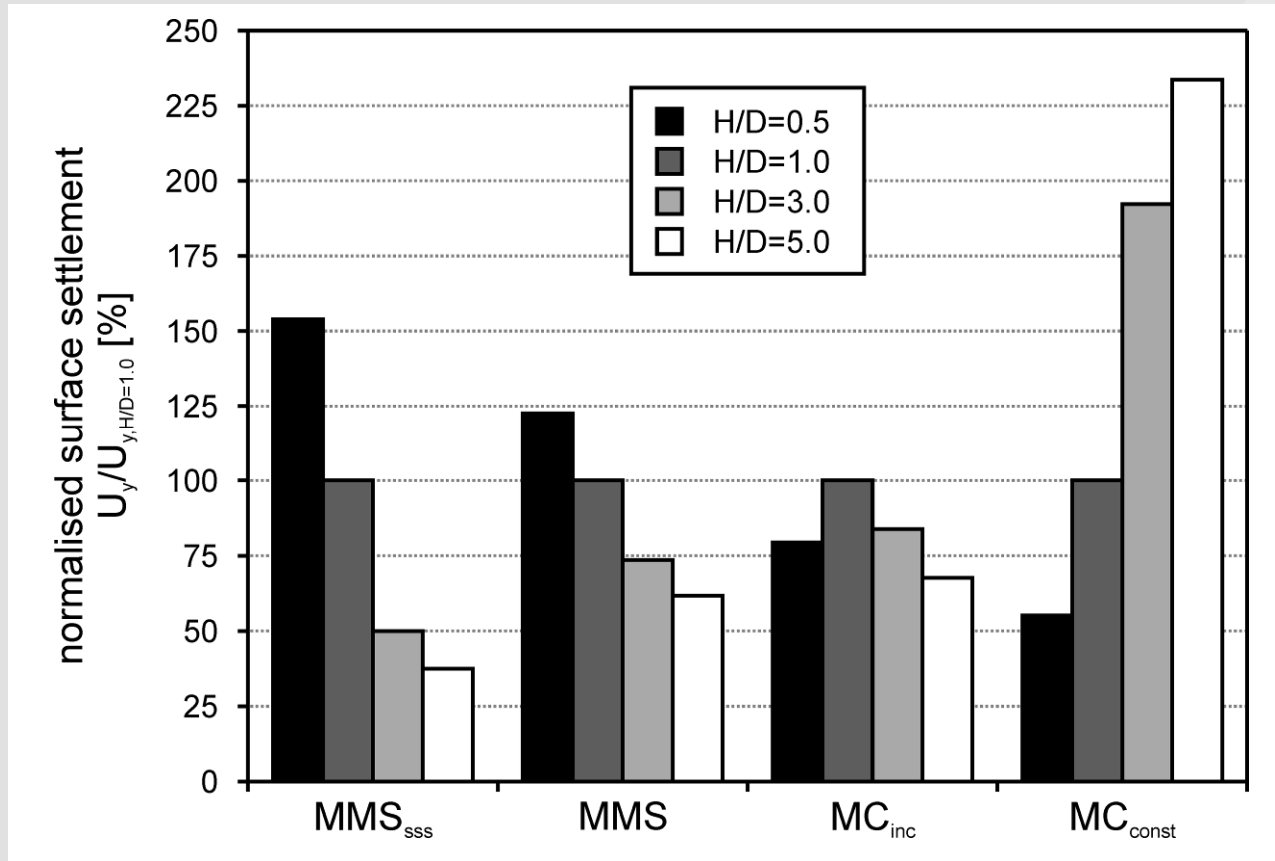

INFLUENCE OF SMALL STRAIN STIFFNESS

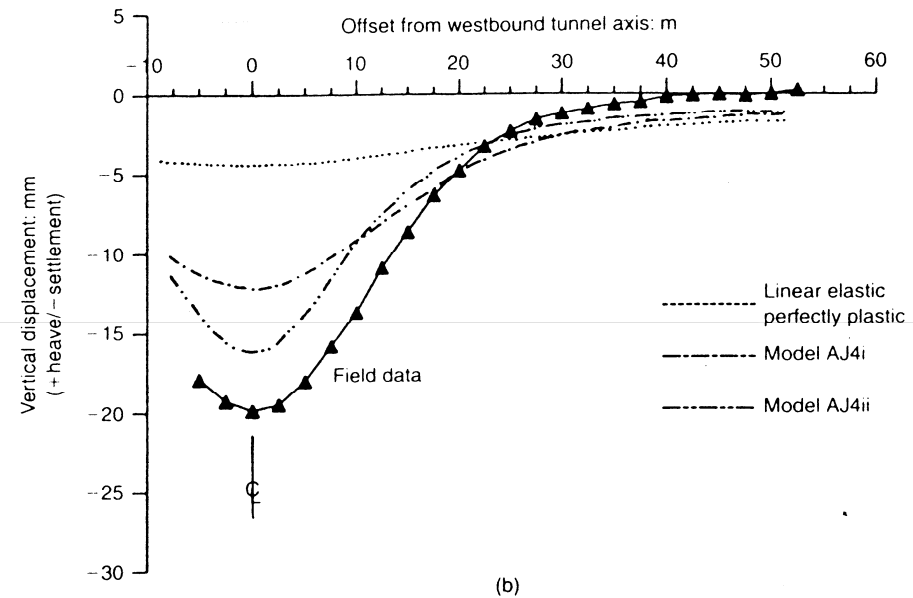
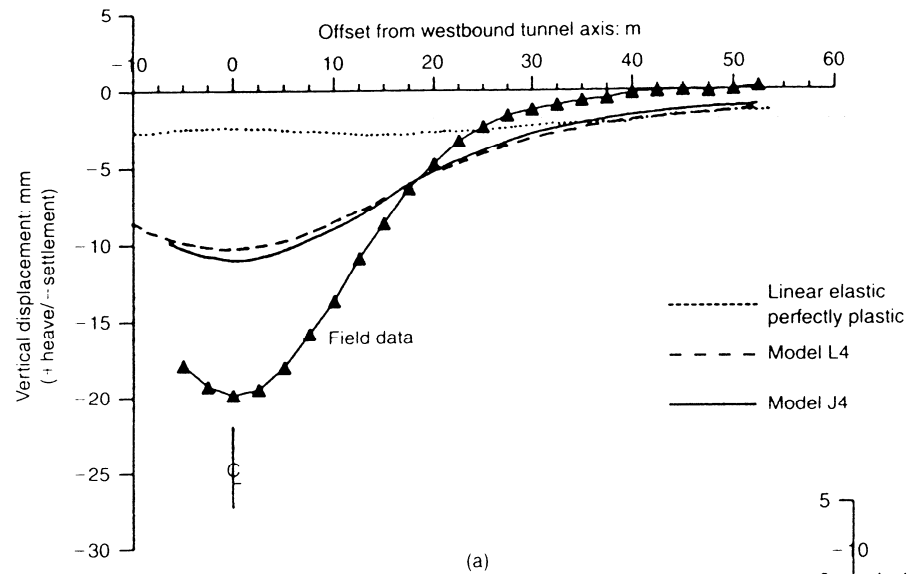

from Addenbrooke, Potts & Puzrin 1997

INFLUENCE OF SMALL STRAIN STIFFNESS

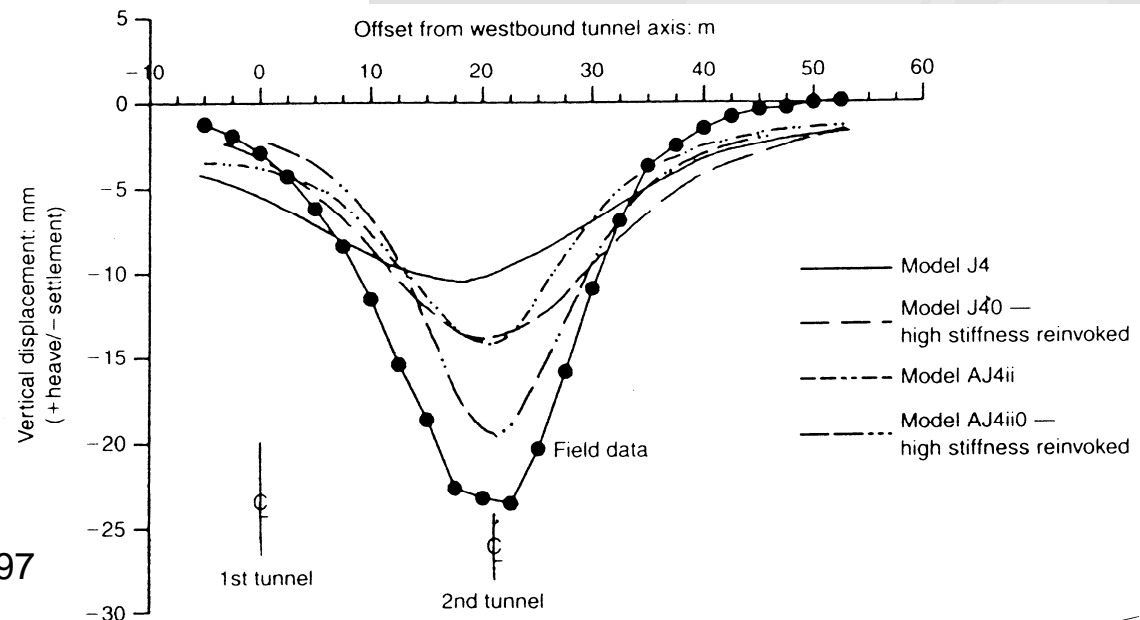
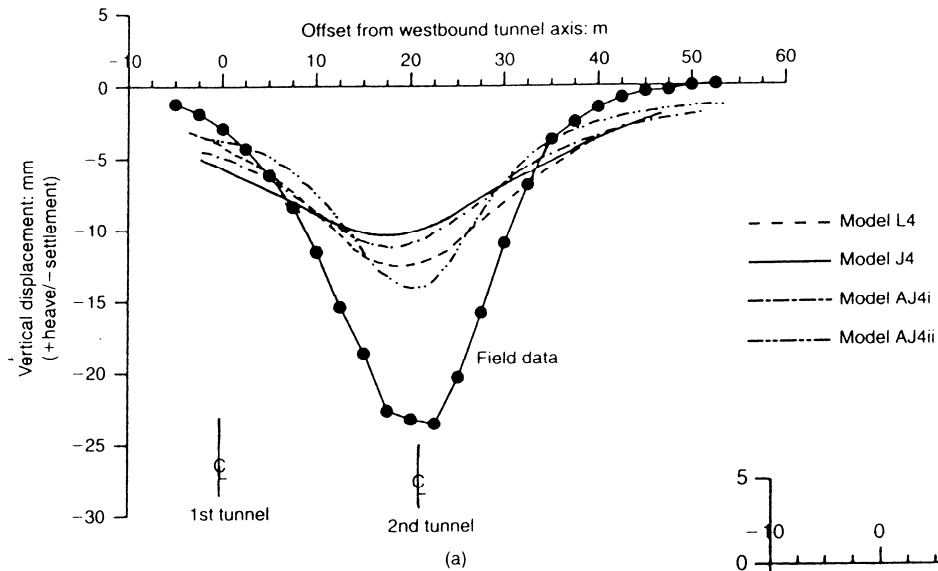

from Addenbrooke, Potts & Puzrin 1997

SMALL STRAIN REGION

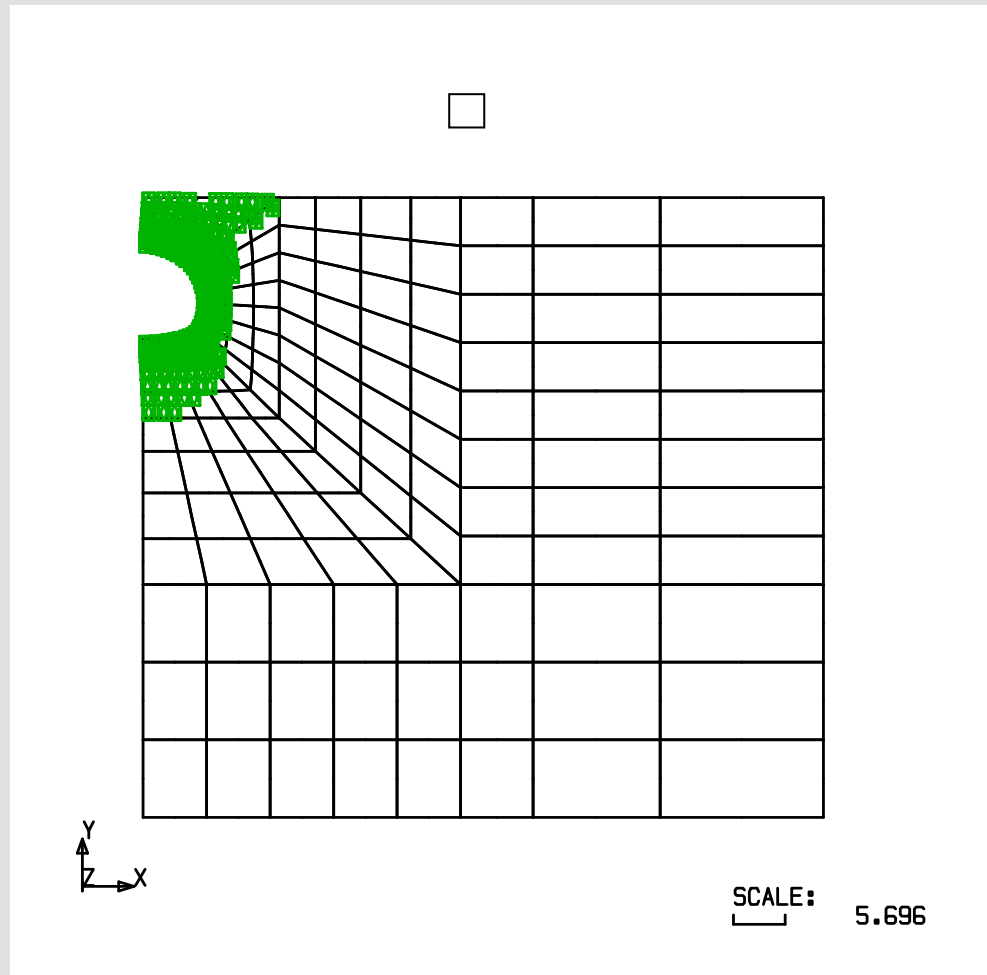

3D MODEL

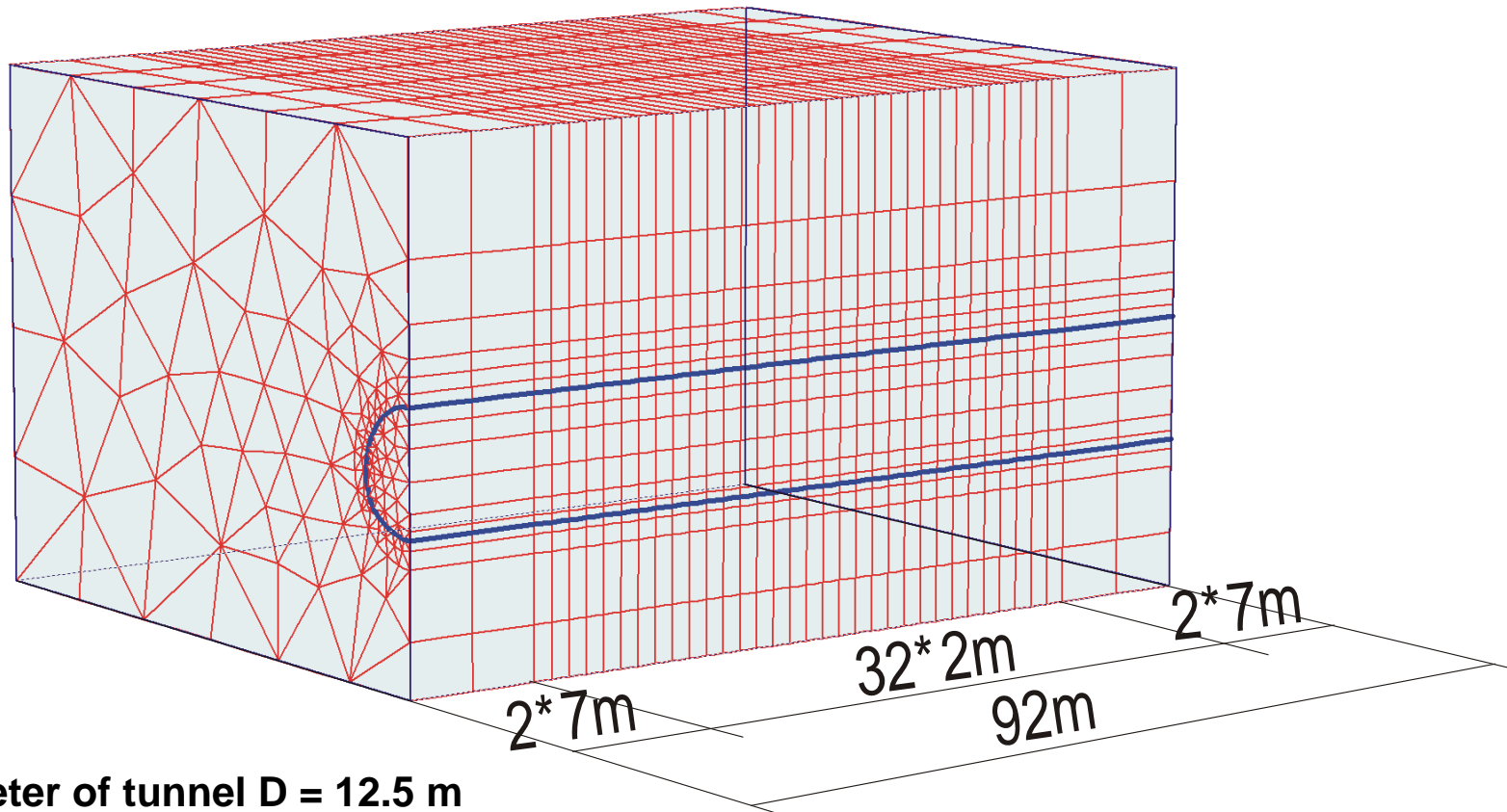

diameter of tunnel $D = 12.5\text{ m}$

still influence of boundary !

START EXCAVATION TOP HEADING

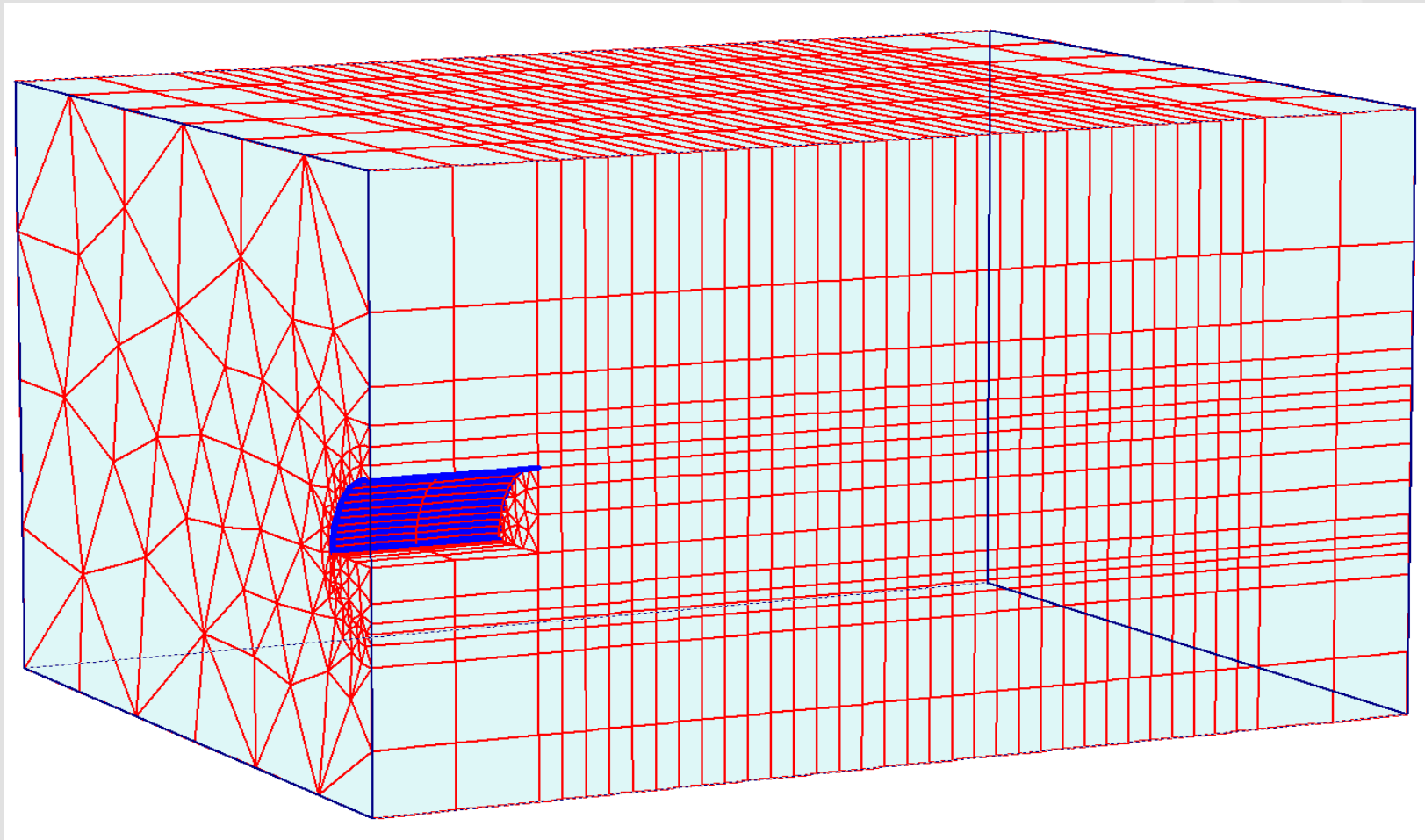

EXCAVATION TOP HEADING

1. round top heading

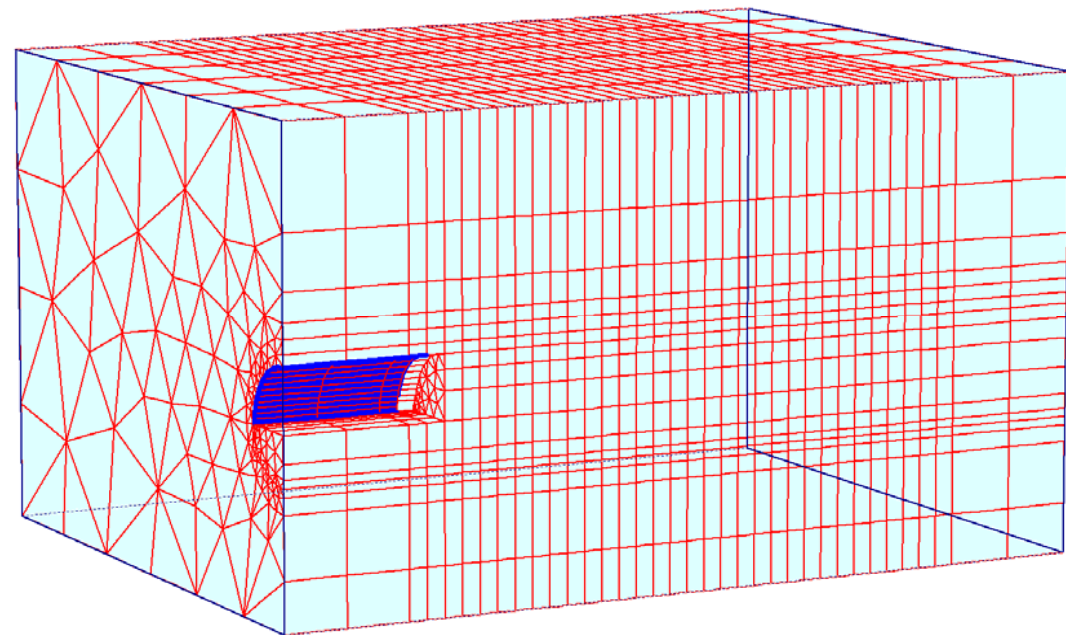
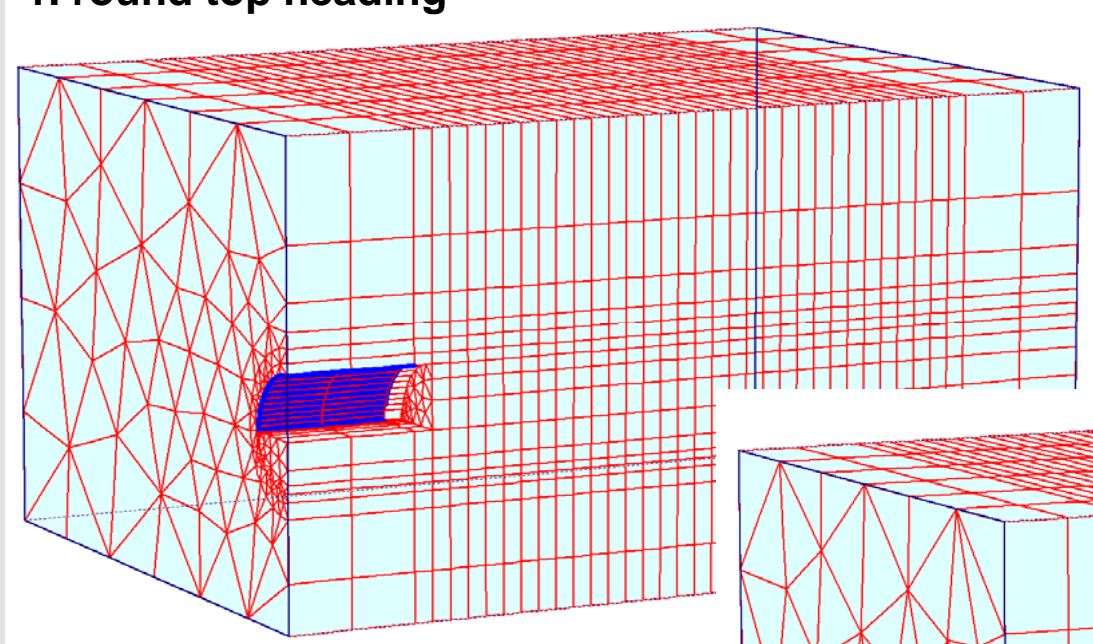

shotcrete in previous section
2. round top heading

EXCAVATION TOP HEADING

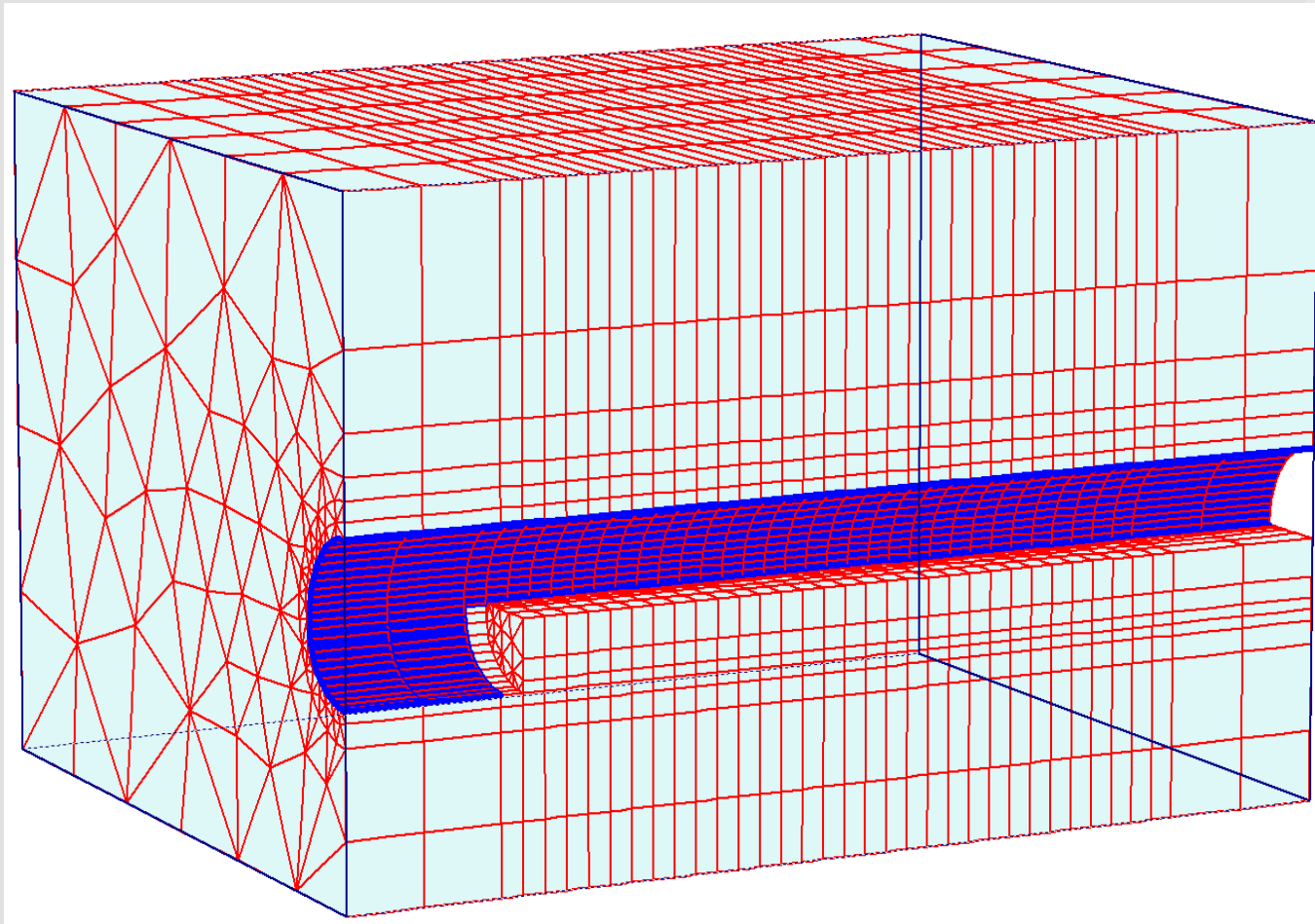

**example top heading excavation
well ahead of bench**

RESULTS 3D MODEL

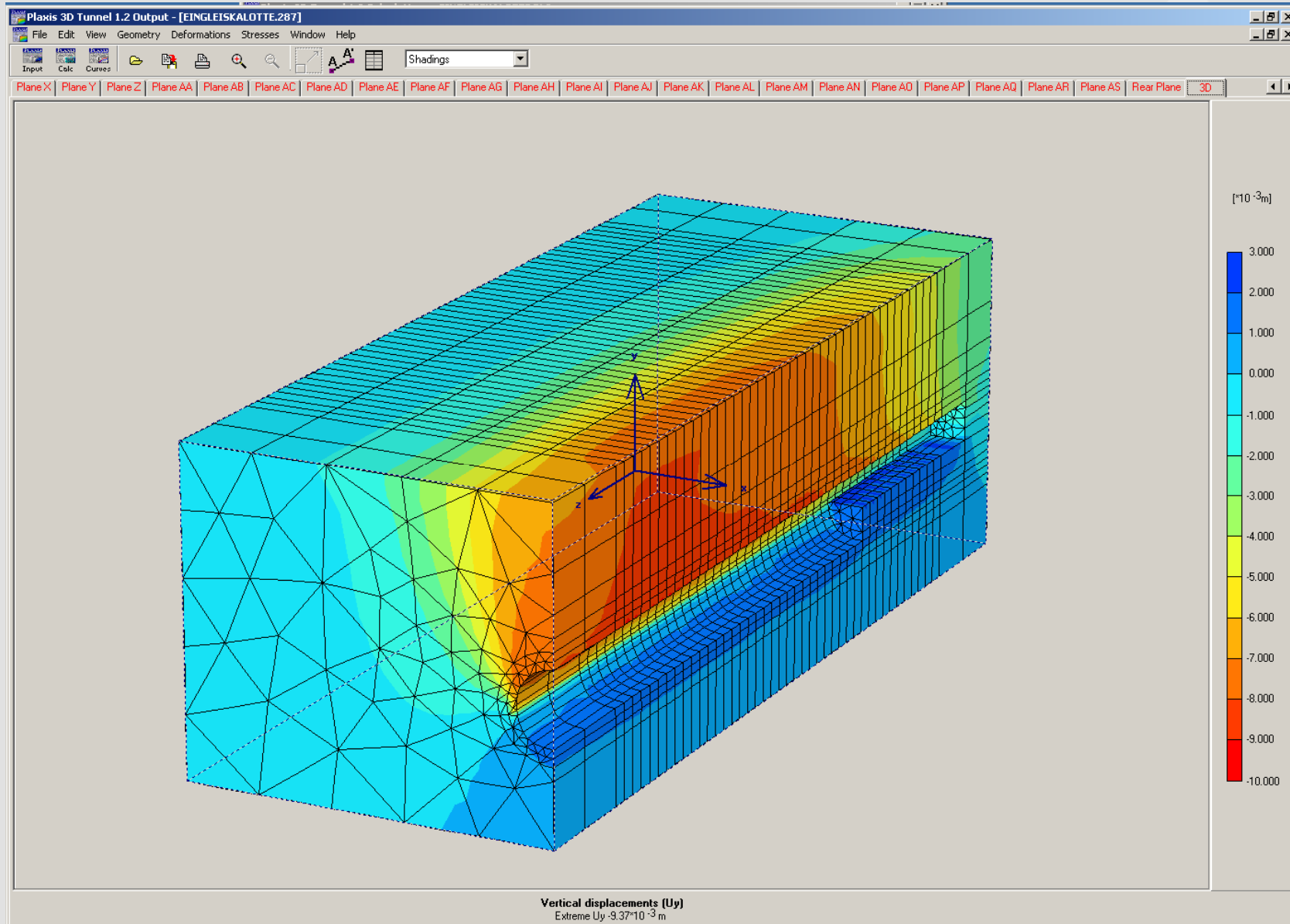

3D MODEL - VERTICAL ARCHING

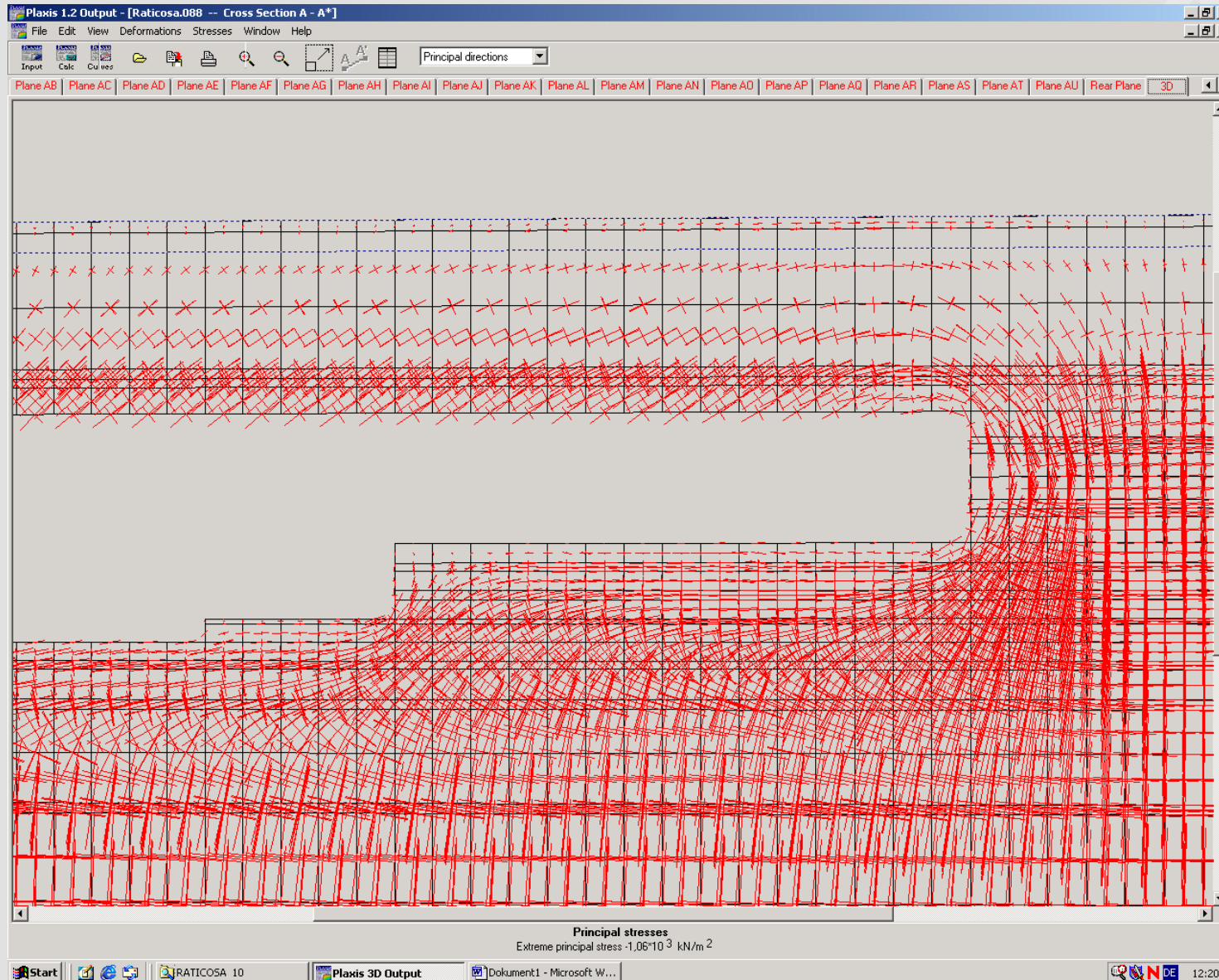

3D MODEL - HORIZONTAL ARCHING

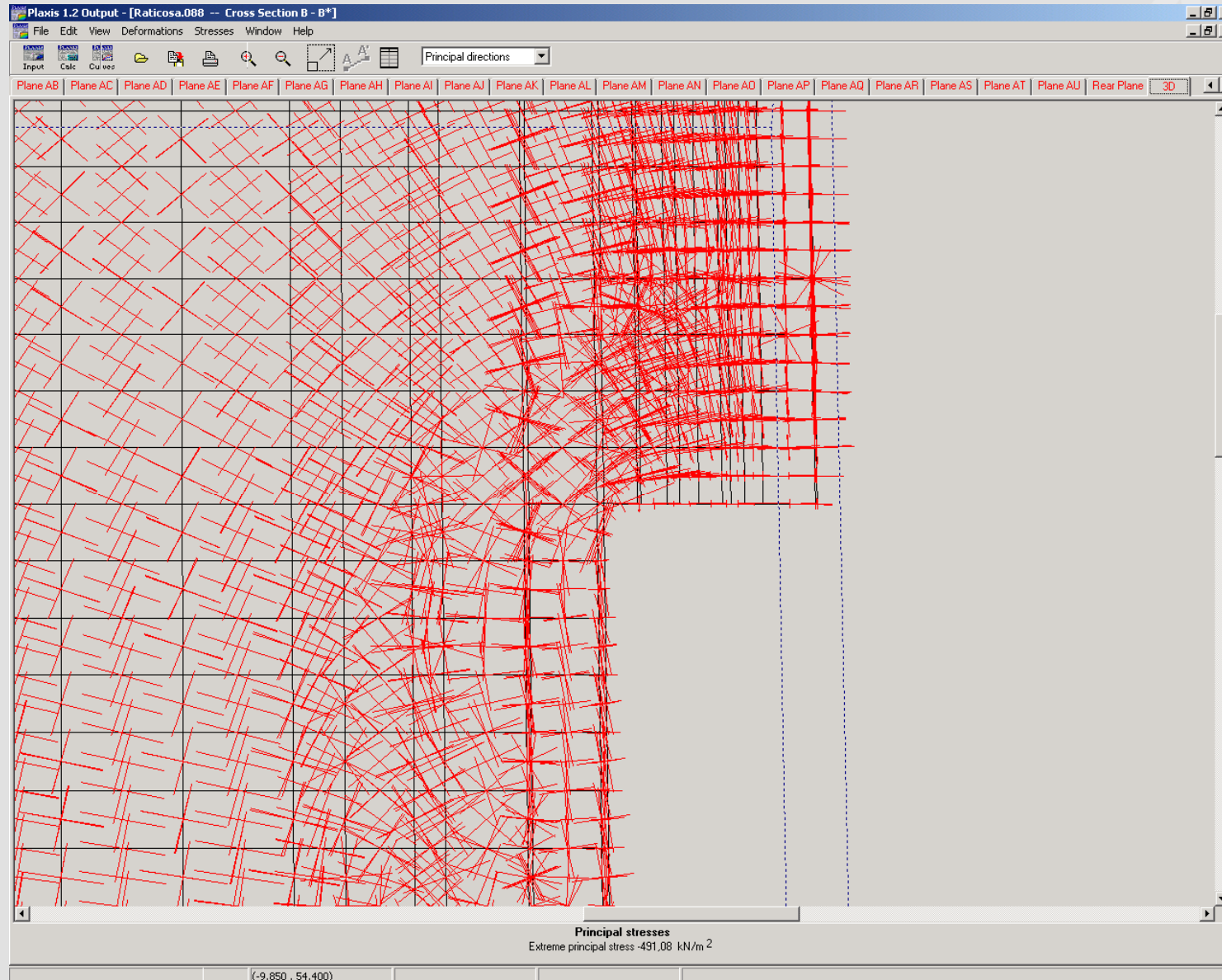

IMPROVED 3D MODEL

diameter of tunnel $D = 9\text{ m}$

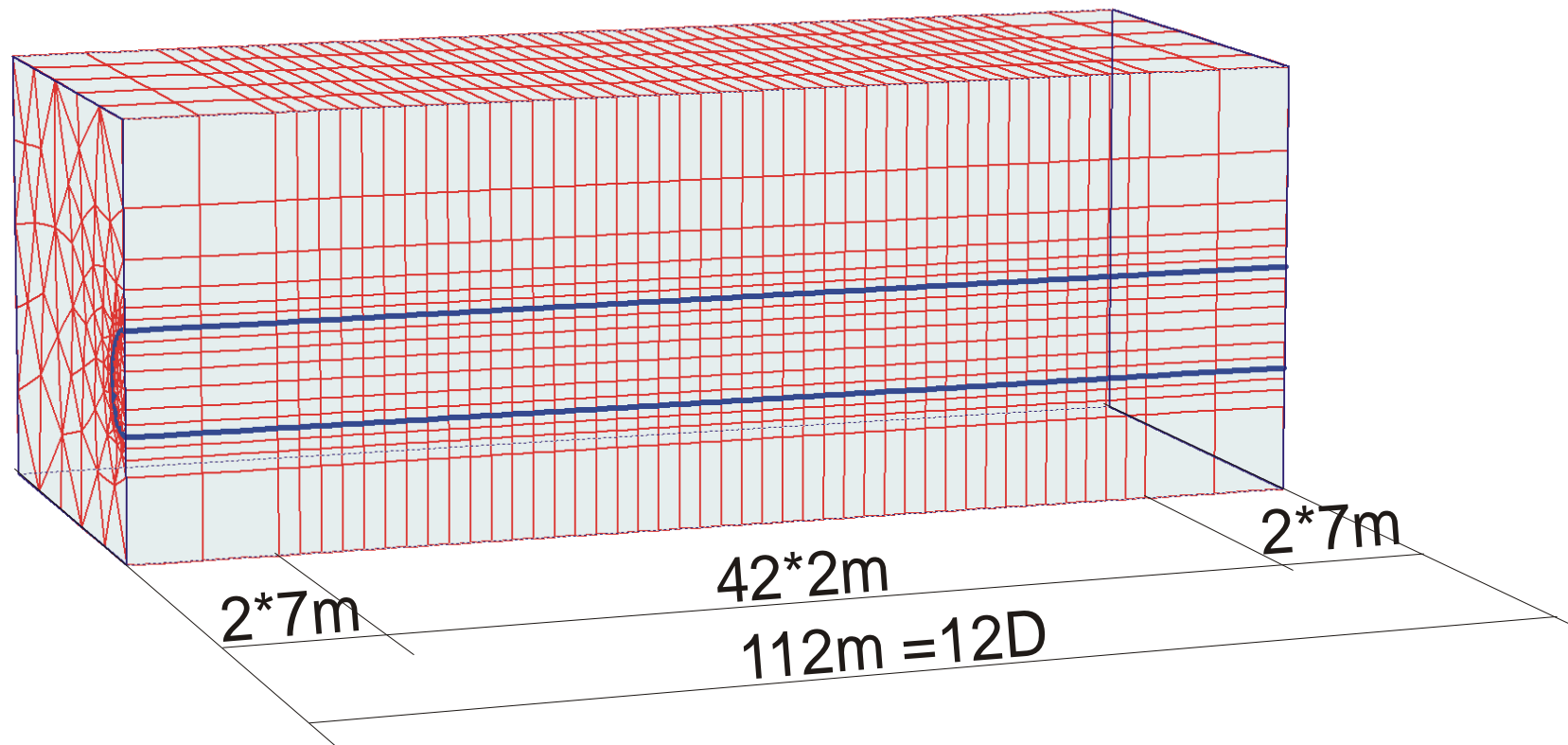

FACE STABILITY



Pictures: IC-CONSULENTEN, WIEN - SALZBURG

SAFETY FACTOR WITH FEM

Definition of safety factor obtained by FEM (**available = unfactored value**)

$$\eta_{fe} = \frac{\tan\varphi_{\text{available}}}{\tan\varphi_{\text{failure}}} = \frac{c_{\text{available}}}{c_{\text{failure}}}$$

Basically 2 possibilities to obtain factor of safety:

- A) Calculation with **unfactored** parameters (yields deformations for service state) > automatic reduction of strength parameters of **soil** until equilibrium is no longer achieved in numerical analysis
(some FE-codes do this automatically > φ/c -reduction technique)
- B) Calculation with **factored** parameters > perform *new* calculation with different factors until equilibrium is no longer achieved in numerical analysis (some codes do this automatically)
(corresponds to concept of partial factors of safety)

see also: e.g. Griffiths (1980), Naylor (1981), Brinkgreve & Bakker (1991), Matsui & San (1992)

3D MODELLING - FACE STABILITY

plotted: mean normal stress $(\sigma_1 + \sigma_2 + \sigma_3)/3$

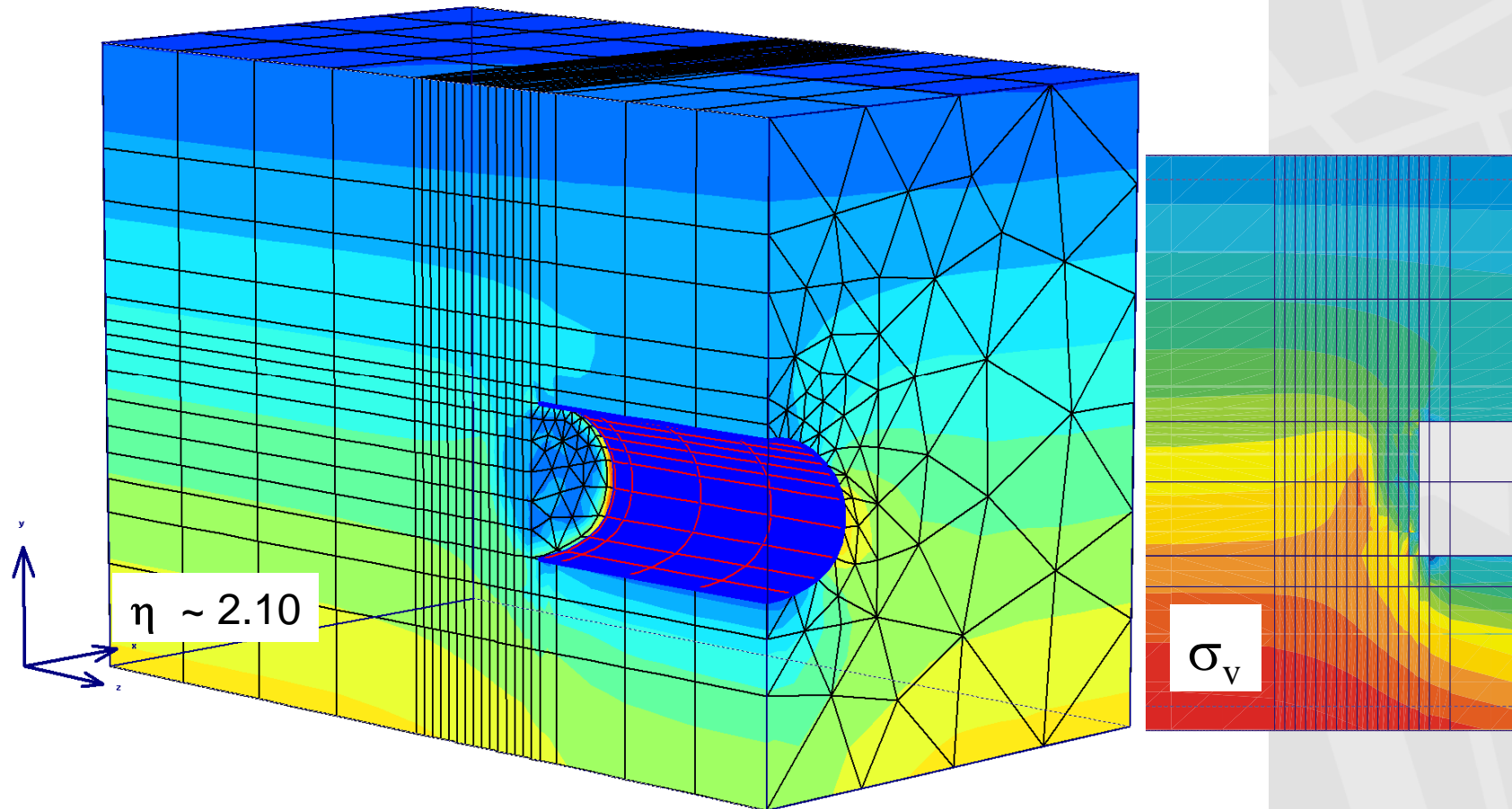

3D MODELLING - FACE STABILITY

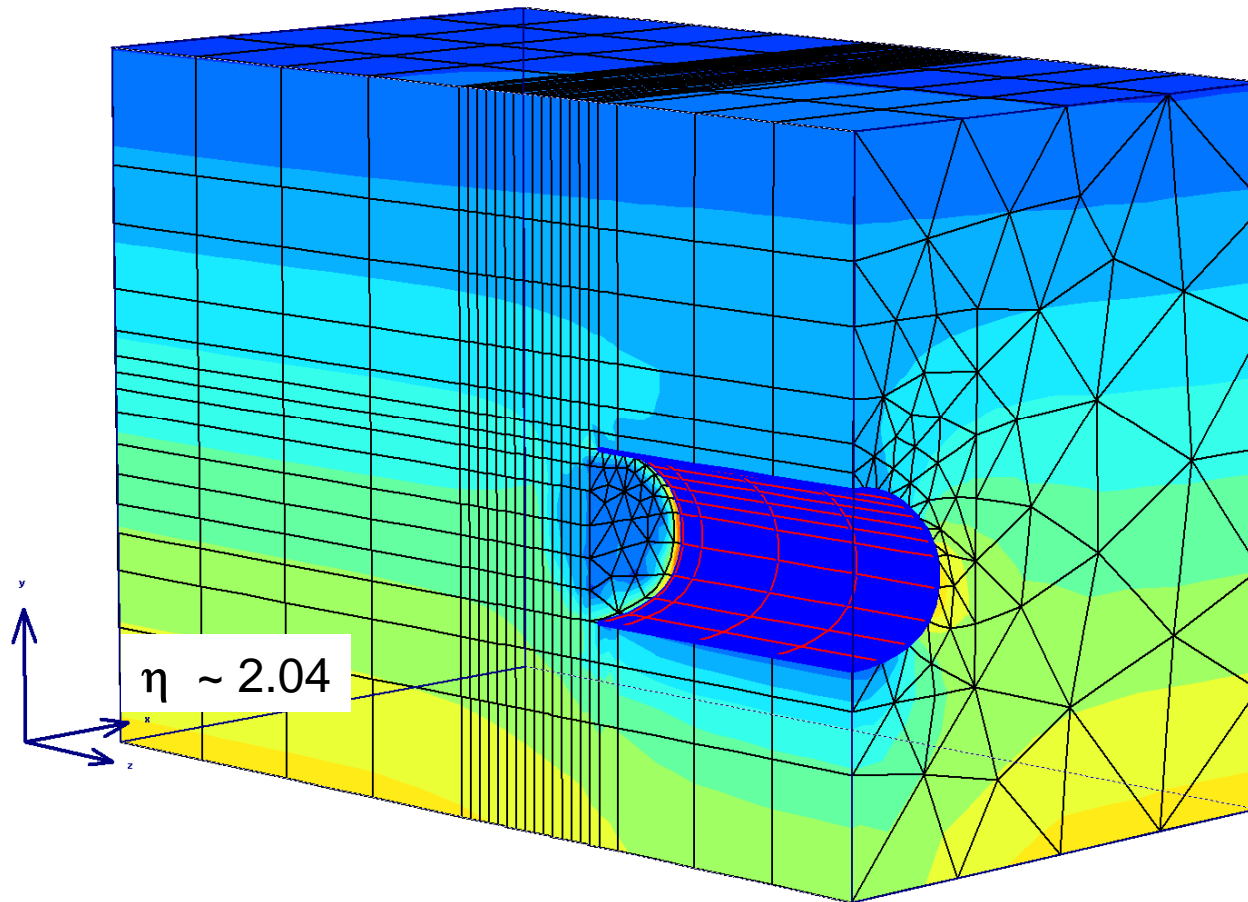

3D MODELLING - FACE STABILITY

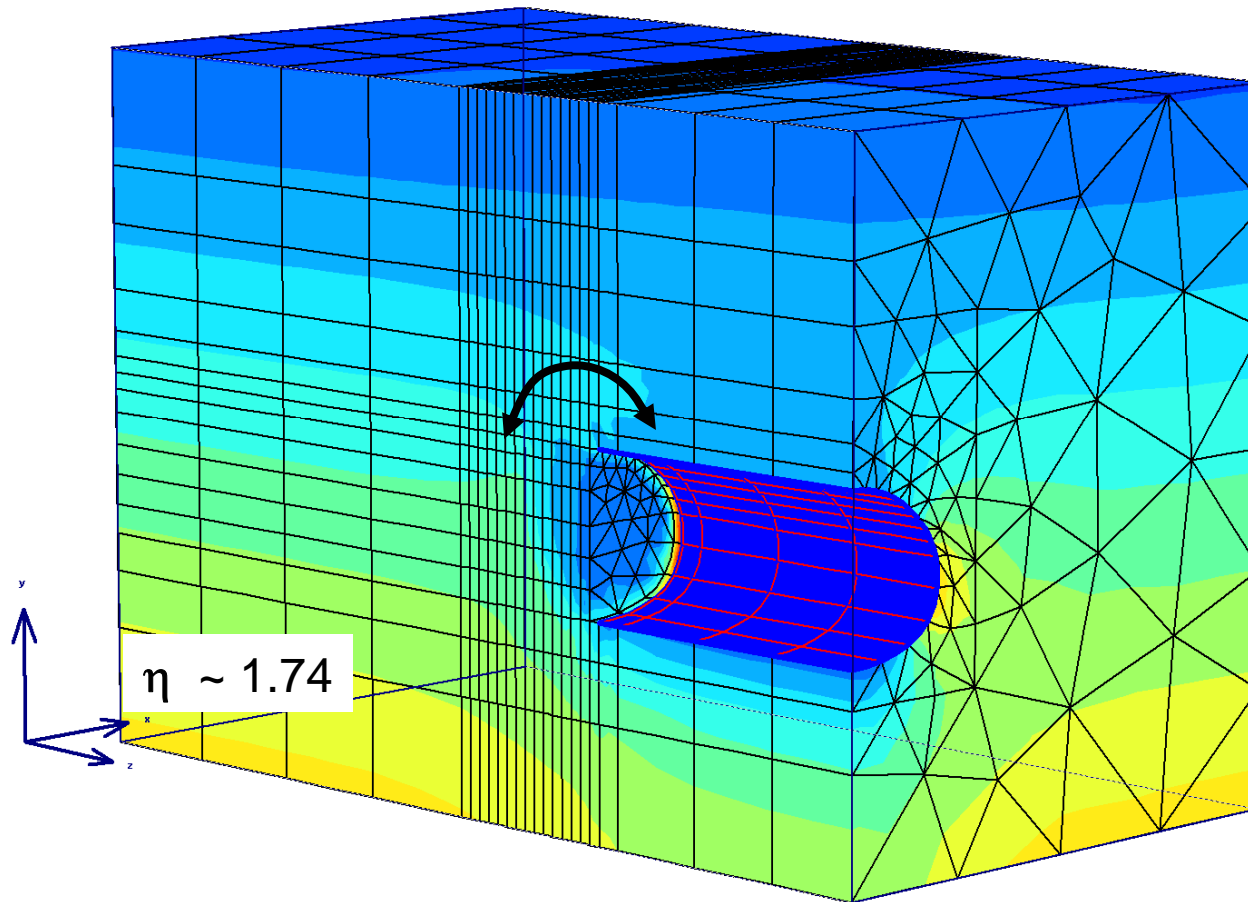

3D MODELLING - FACE STABILITY

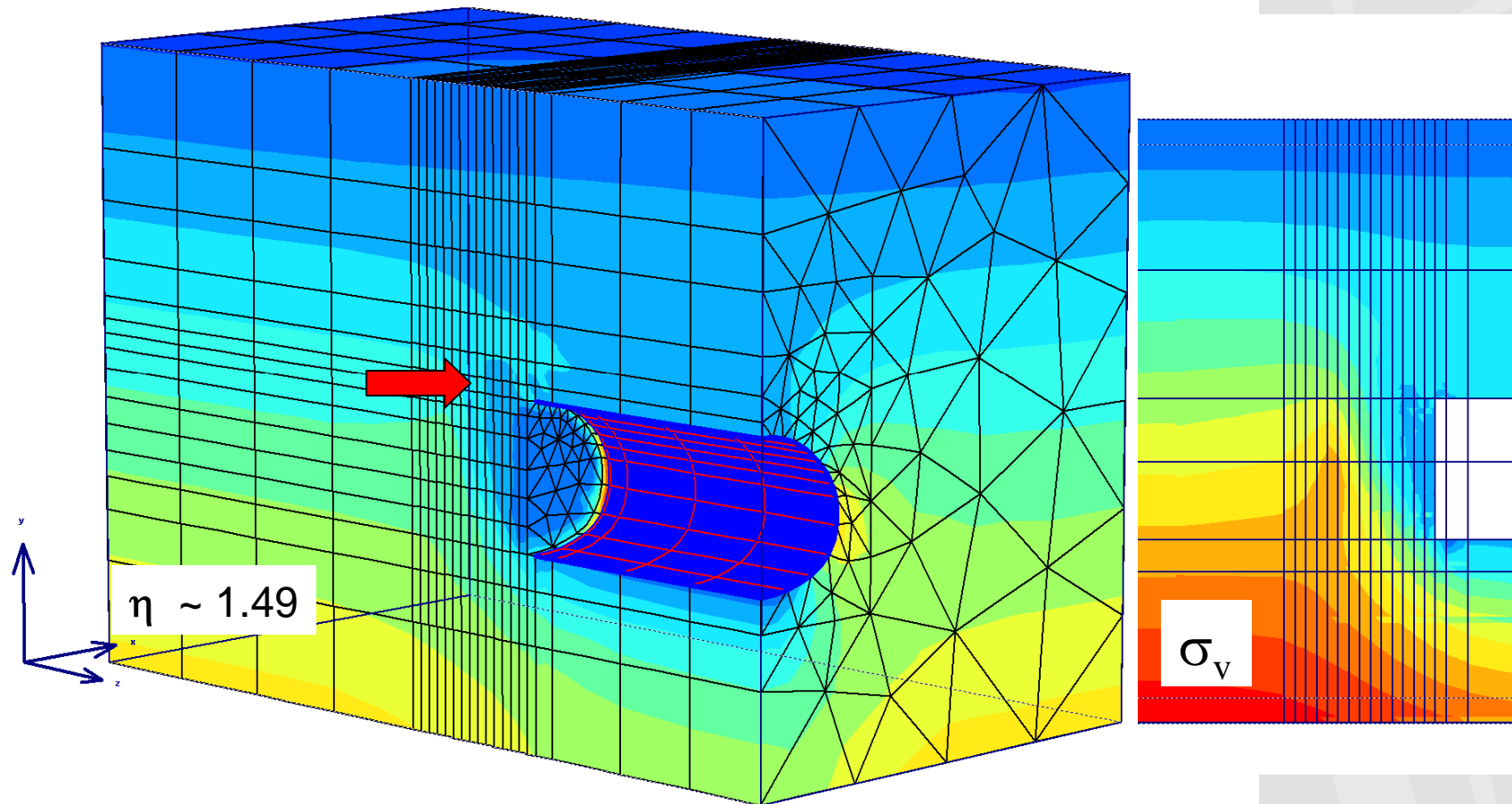

3D MODELLING - FACE STABILITY

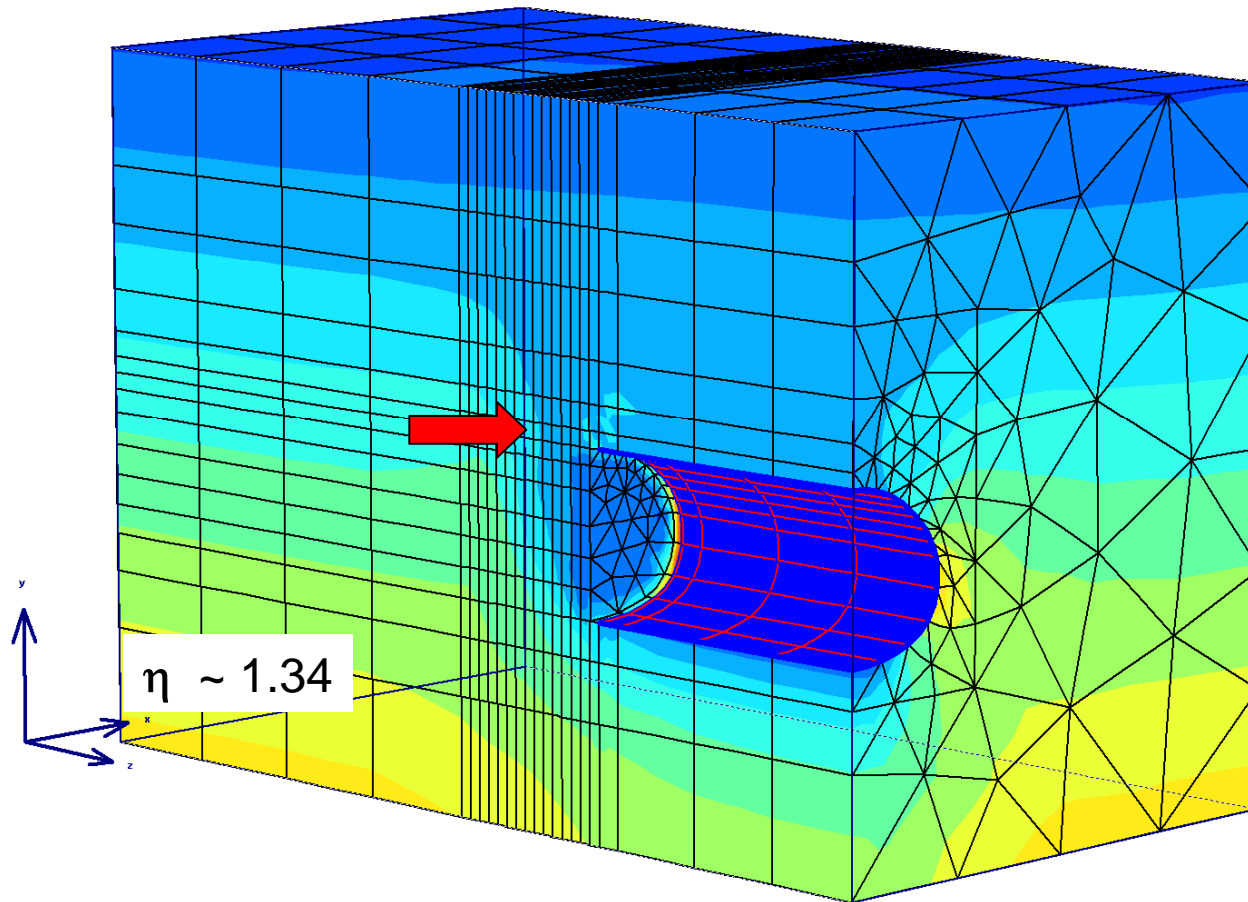

3D MODELLING - FACE STABILITY

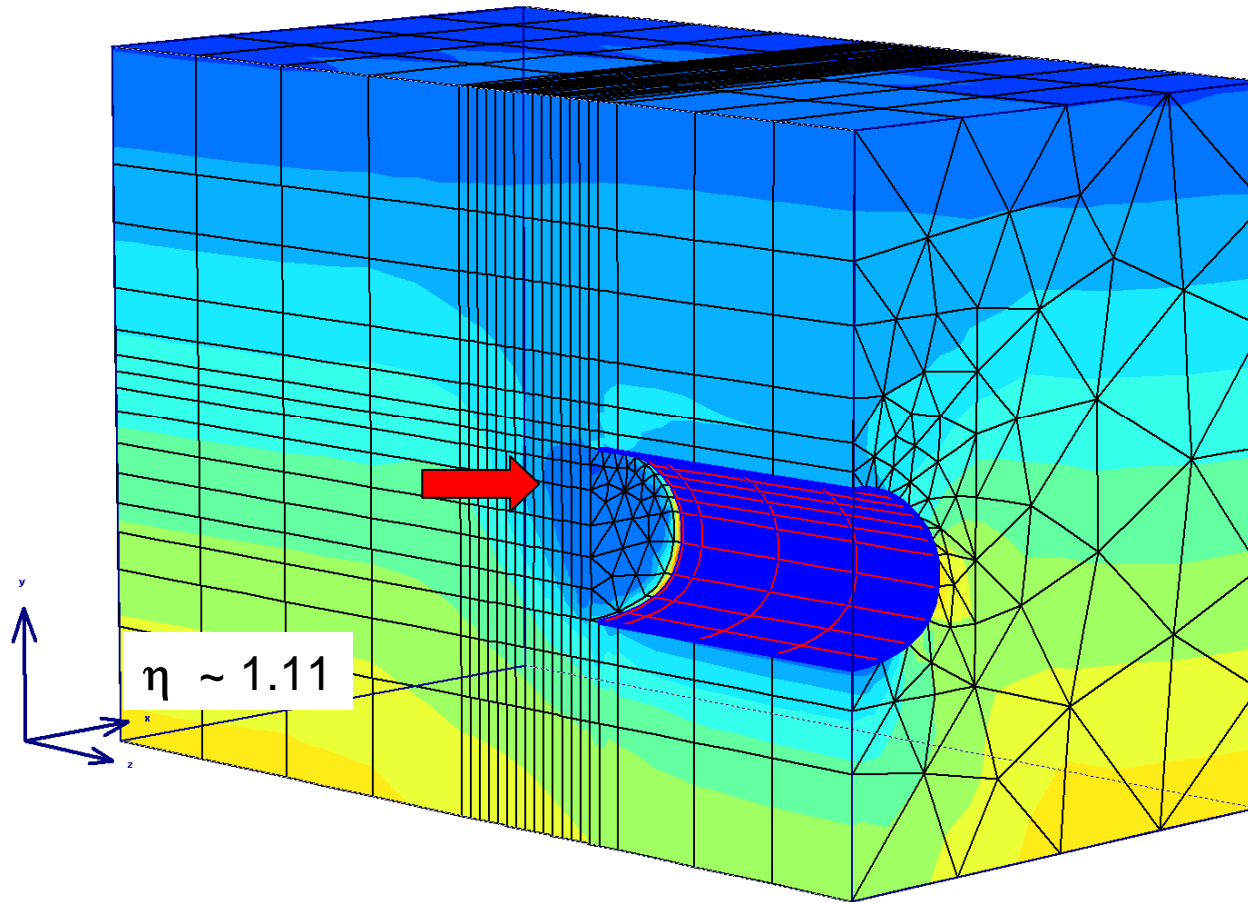

3D MODELLING - FACE STABILITY

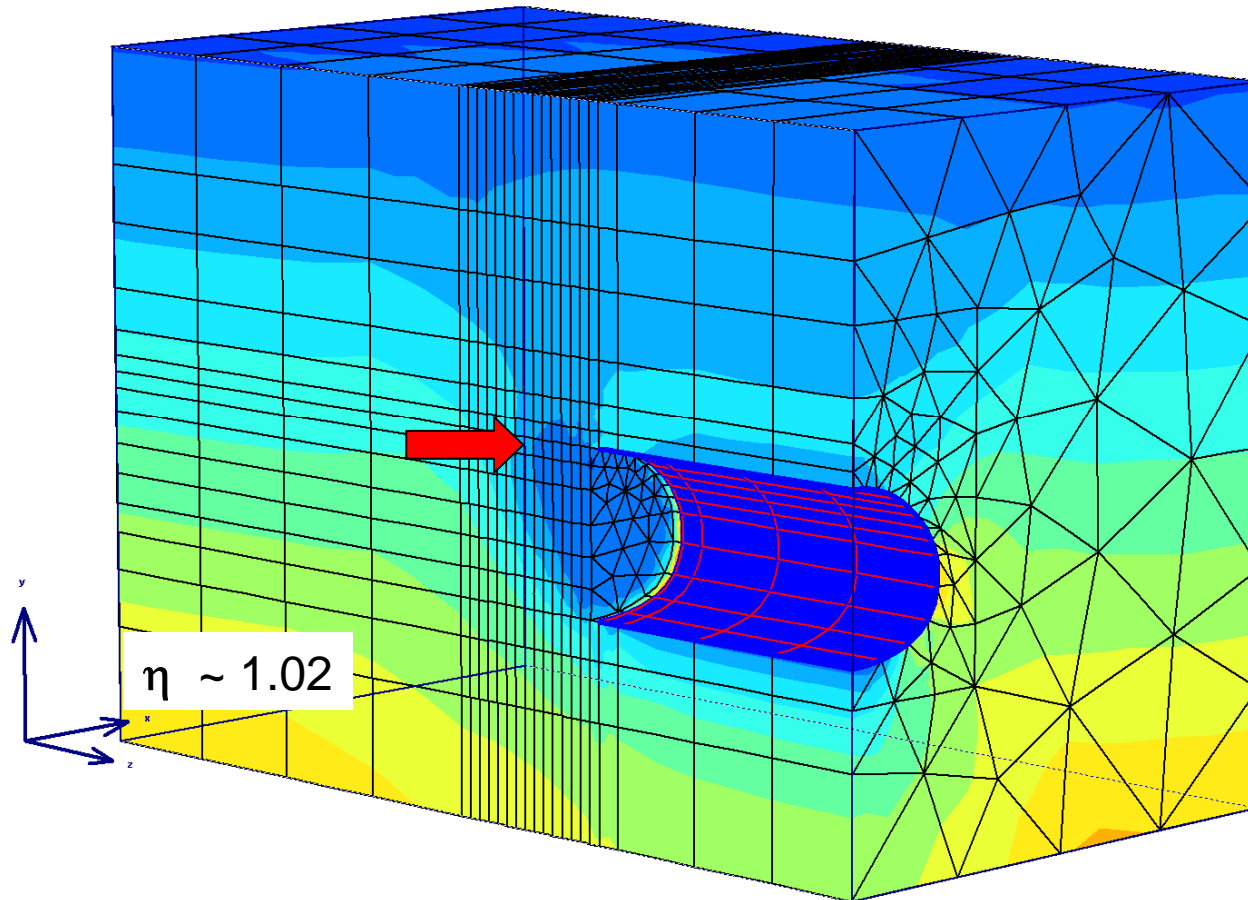

3D MODELLING - FACE STABILITY

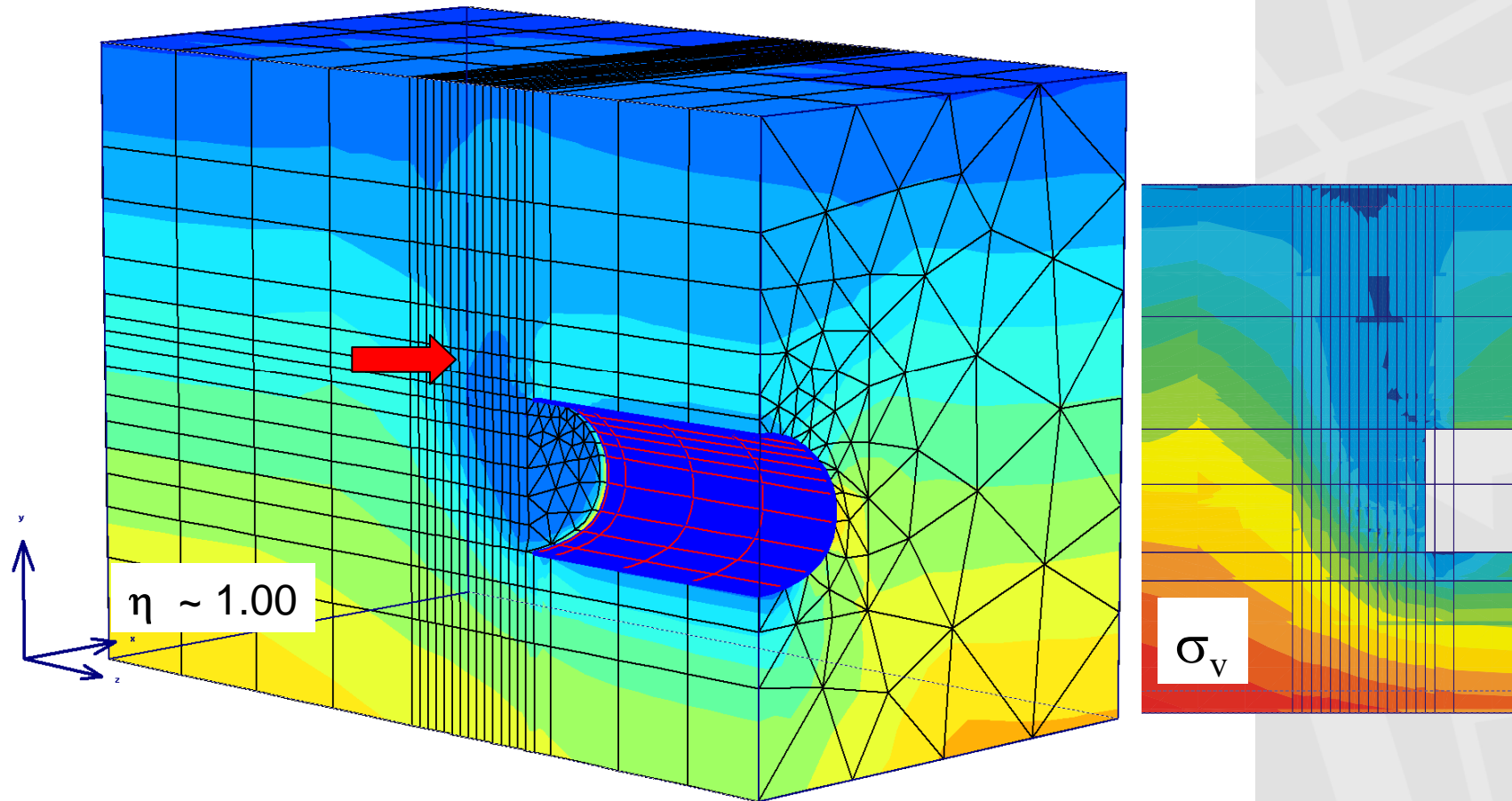

3D MODELLING - FACE STABILITY

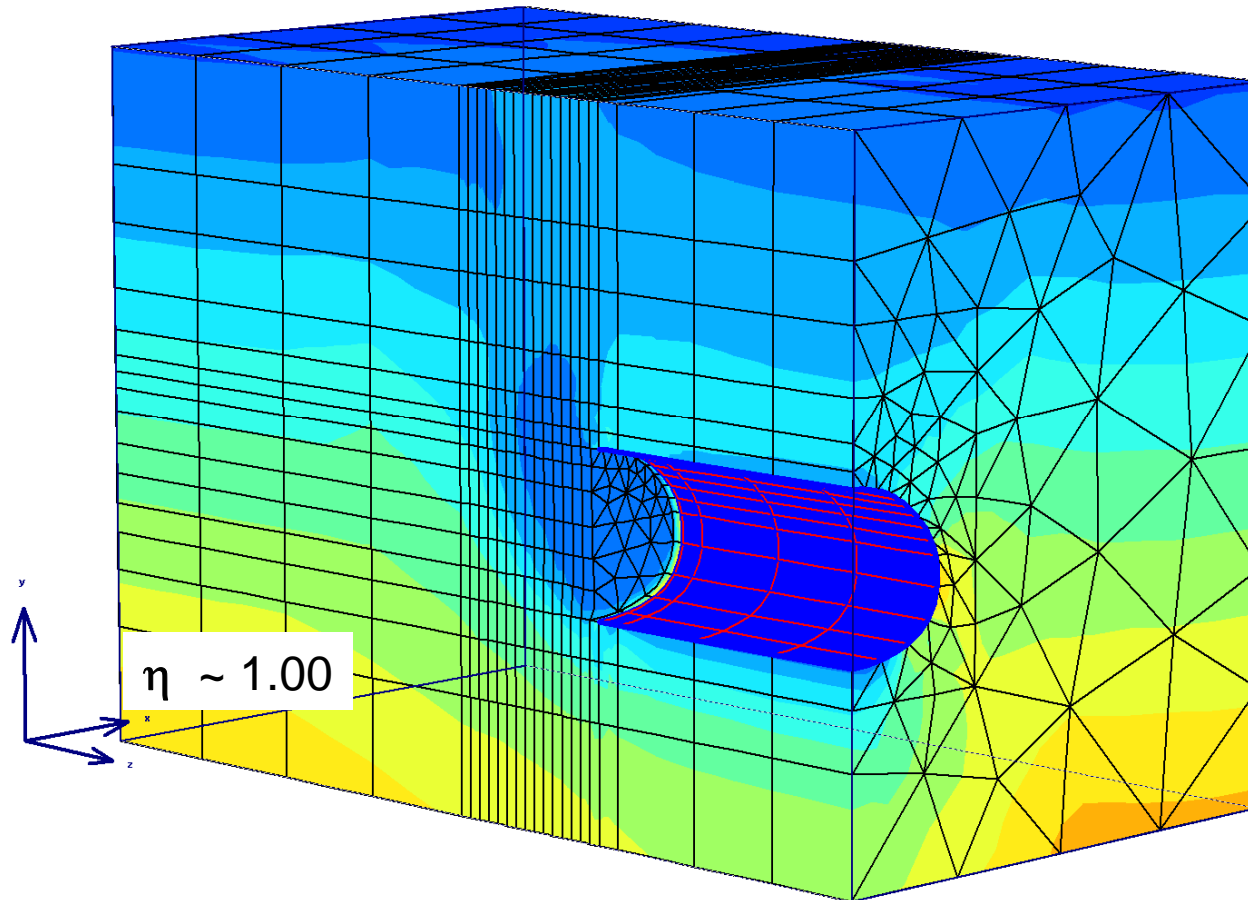

3D MODELLING - FACE STABILITY

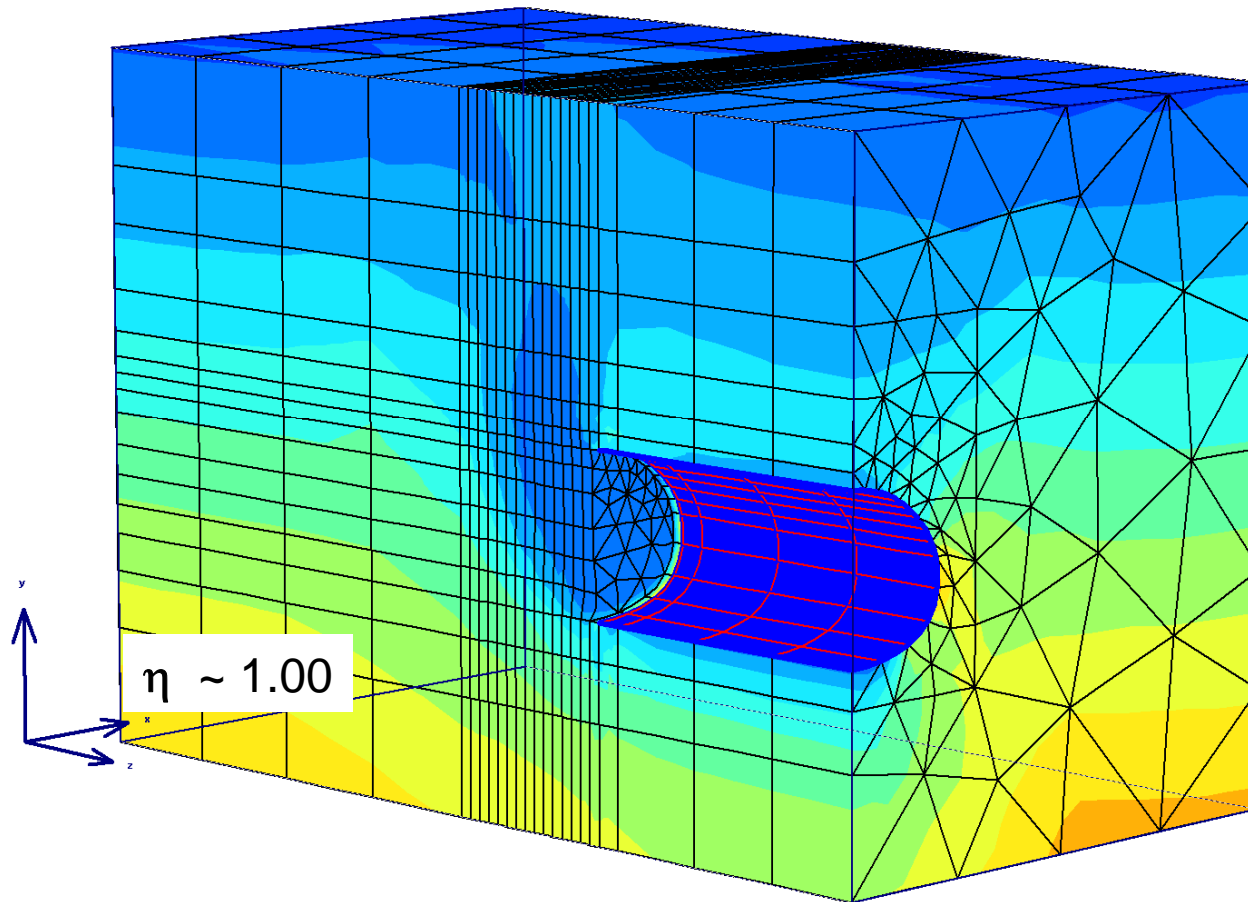

3D MODELLING - FACE STABILITY

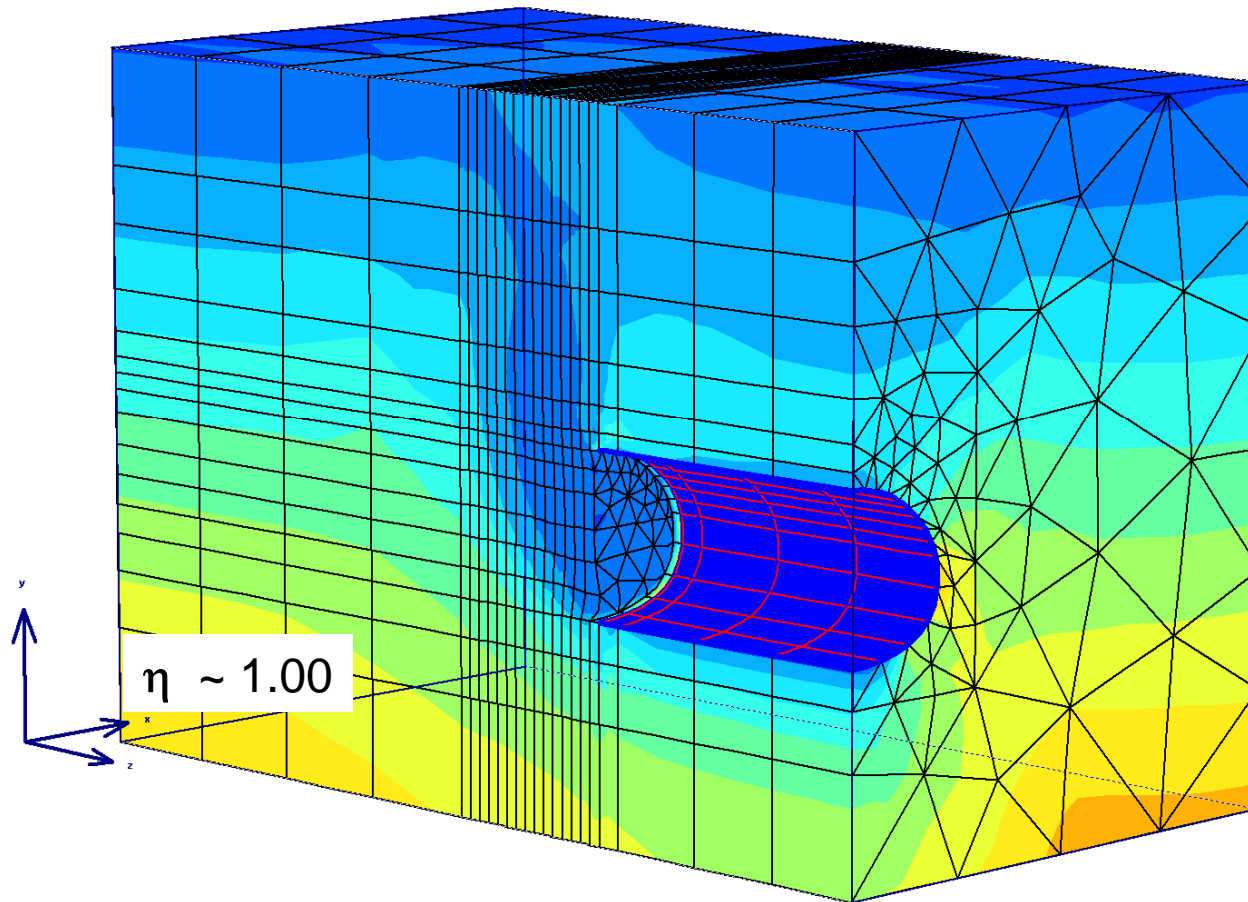

3D MODELLING - FACE STABILITY

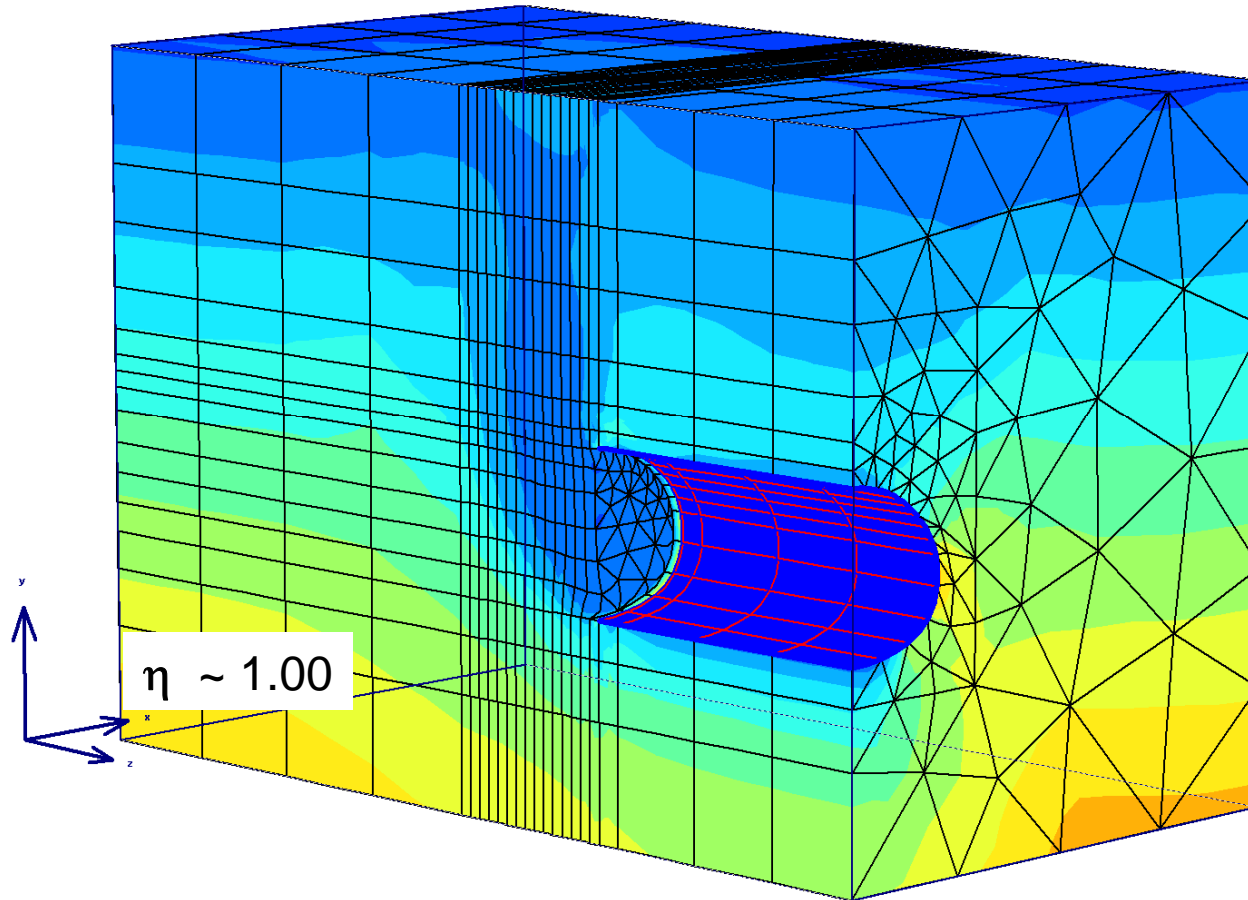

3D MODELLING - FACE STABILITY

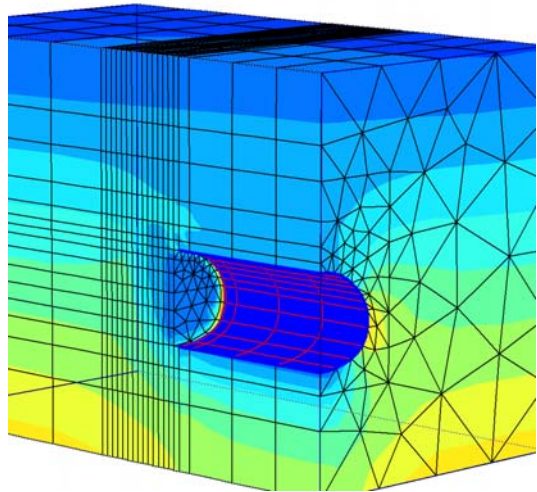

$\eta > 1.5$

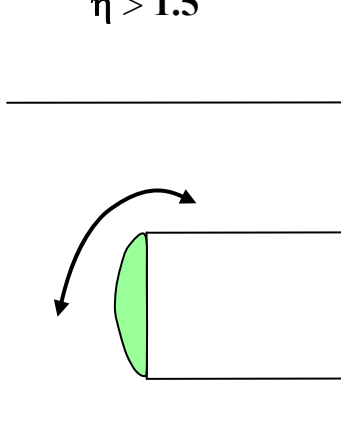

working load condition

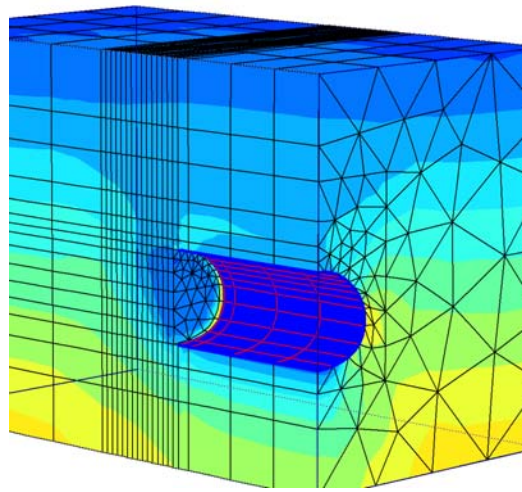

$\eta \sim 1.1$

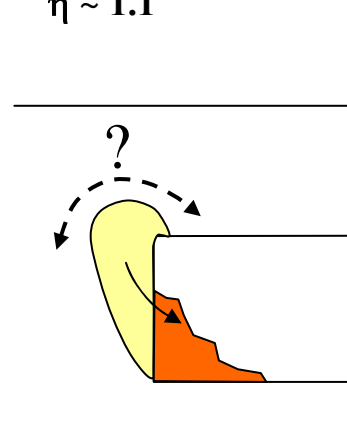

failure condition I

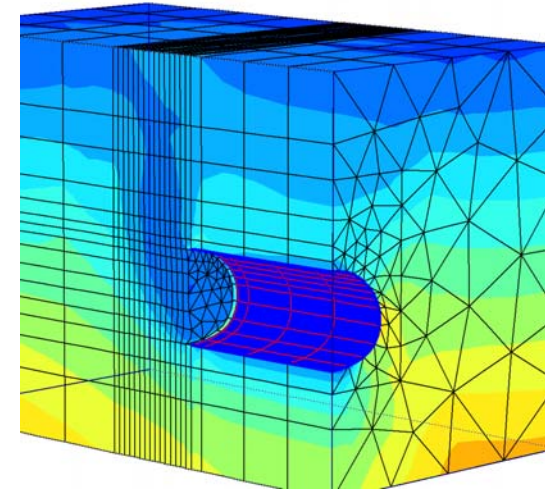

$\eta \sim 1.0$

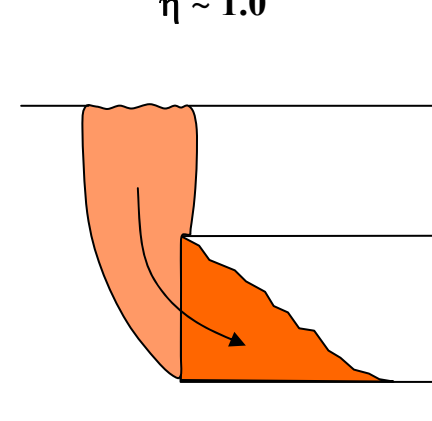

failure condition II

3D MODELLING - FACE STABILITY

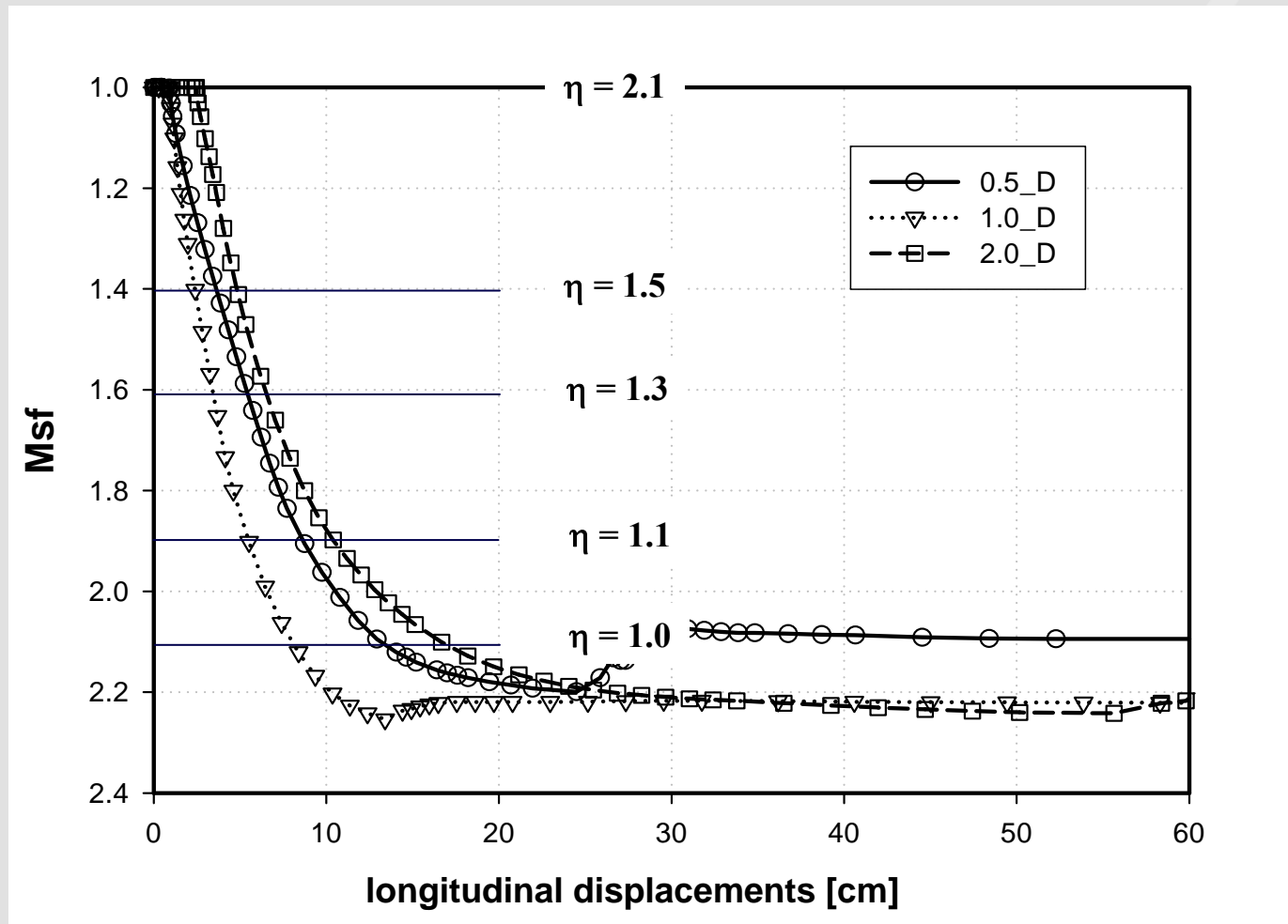

SUMMARY FROM FACE STABILITY STUDY

Overburden height not critical for $\varphi > 20^\circ$

(see also Vermeer, Ruse, Marcher ; Mayer et al., etc.)

Tunnel diameter and cohesion important ($\varphi > 20^\circ$)

approximate relationship:

$$c_{\text{required}} = \gamma \cdot D/10 \quad (\text{Vermeer, Ruse, Marcher})$$

Deformation (longitudinal) even for failure condition I relatively small

**Up to failure condition II displacements increase progressively,
but safety margin is already low at failure condition I**

FACE REINFORCEMENT

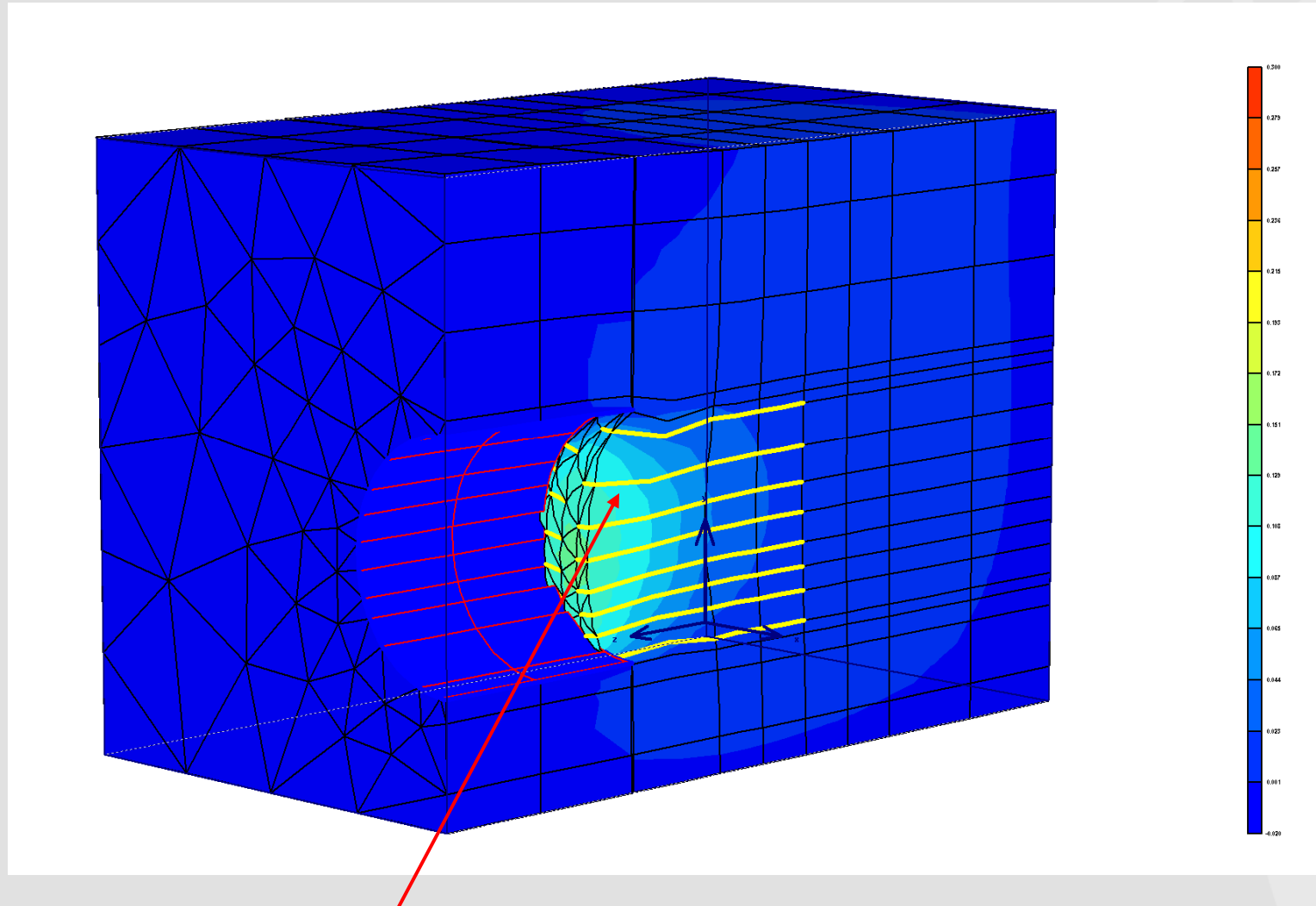

Face reinforcement with geotextile-elements

FACE REINFORCEMENT

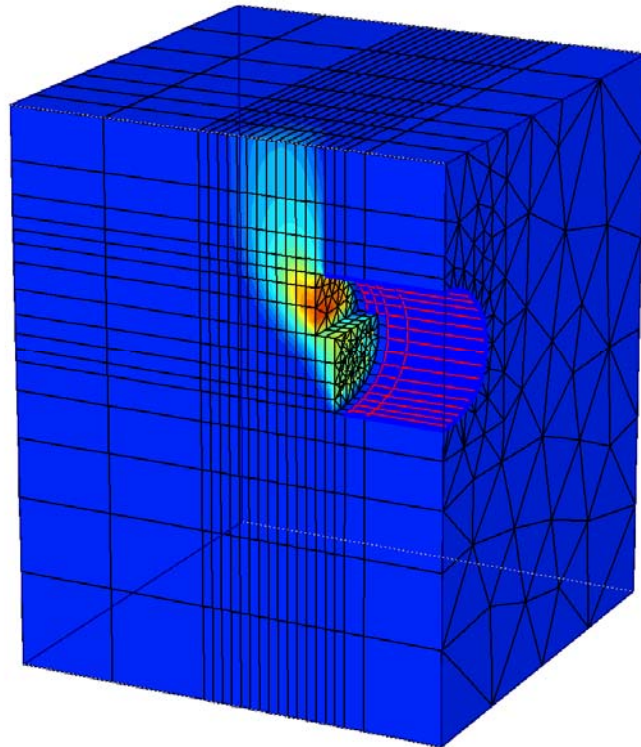

anchor length 12 m

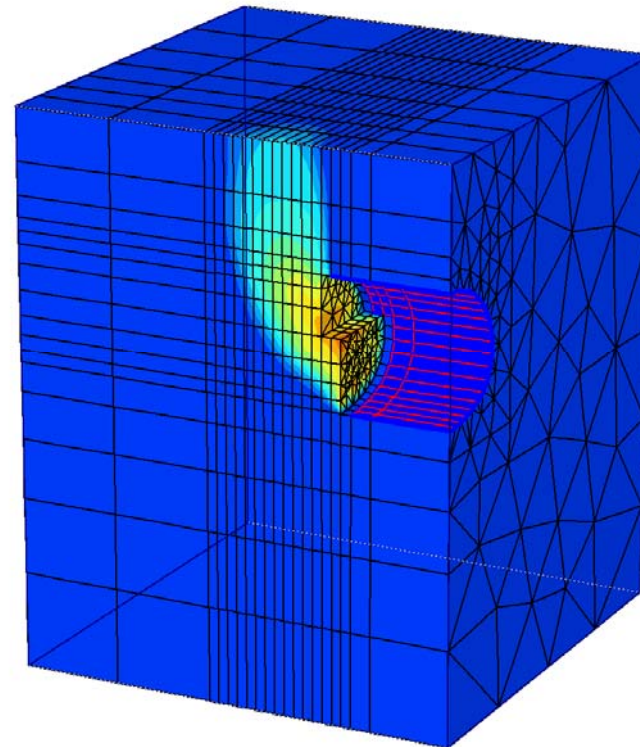

anchor length 4 m

FACE REINFORCEMENT

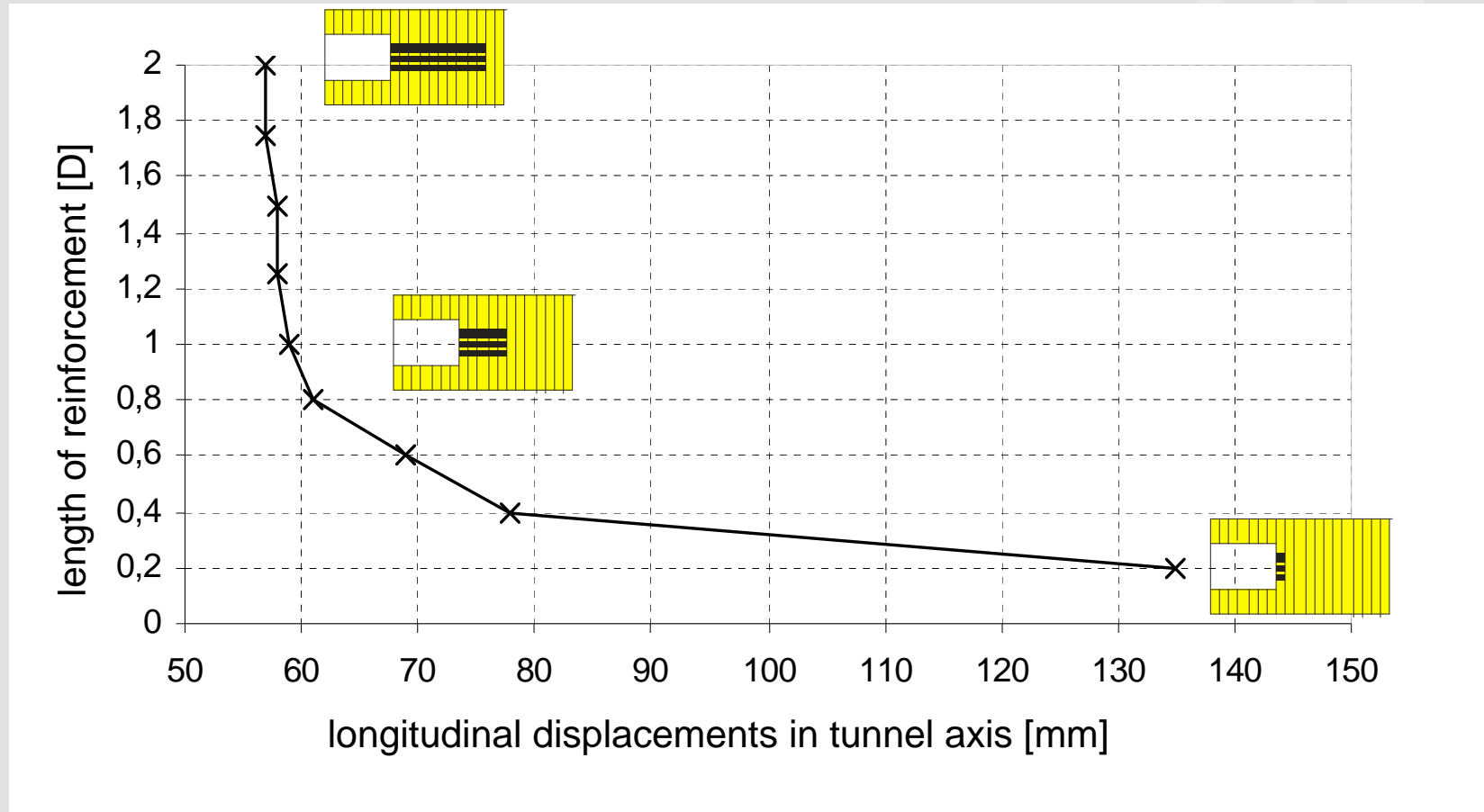

Face reinforcement with geotextile-elements

SUMMARY

- **2D-analysis state-of-the-art in practice**
 - > **prerelaxation methods**
(load reduction method – stiffness reduction method)
- **Attention with boundary conditions**
(in particular with MC-models)
- **Full 3D analysis for complex excavation sequence**
leads to very large models
- **For face stability 3D - analysis required**