



International Society for Soil Mechanics and Geotechnical Engineering

www.issmge.org

A Message from the President
90 Day Progress Report

By Jean-Louis Briaud

briaud@tamu.edu

INSIDE THIS ISSUE

- 1 A Message from the President
- 5 Views of Young Geotechnical Engineers
- 8 Reminiscences
- 11 Case History
- 19 TC Activity
- 22 News
- 30 Announcement
- 32 Editorial Remarks
- 33 Event Diary
- 36 Corporate Members

**Dear Colleagues,**

You elected me approximately 90 days ago and I can assure you that it was one of the major highlights of my professional career. I appreciated the large number of congratulatory emails, letters, and phone calls that I received. I tried to answer every one of them but may have missed a few. I also appreciated the photos that you sent me of the conference as I was so busy that I did not have time to take any pictures or even go see the Pyramids. But our hosts, led by Mamdouh Hamza, deserve so much credit for all the work they did and the great success of the Alexandria Conference. I enjoyed myself thoroughly.

As soon as I was elected I started to work and this is a short report on the progress I have made over the last 90 days with the help of the ISSMGE Board, the Secretary General, and many of you as well. This first effort is part of my broader vision for the next four years which you can find on my web site in a few languages (<https://ceprofs.civil.tamu.edu/briaud/>).

EDITORIAL BOARD

Jean-Louis Briaud
Osamu Kusakabe
Ikuo Towhata
Neil Taylor
Pedro Sêco e Pinto
Pongsakorn Punrattanasin
Deepankar Choudhury
Imen Said
Makoto Namba
Erdin Ibraim
Cholachat Rujikiatkamjorn

Three new Board Level Committees (BLCs) started

The new organization chart for ISSMGE is shown in the Figure where you can see the role played by the three Board Level Committees (BLCs). In order to start the BLCs I have accomplished the following.

1. Worked with the ISSMGE Board Members to set up the three Board Level Committees that I presented to you in Alexandria and wrote the charges for the three BLCs (let me know if you wish a copy of the charges)
2. Contacted the people whose names were suggested to take the lead of these three very important committees
3. After convincing them, and after collecting comments on the draft charges, rewrote the charges and proposed the creation of the 3 BLCs for an official vote of the ISSMGE Board.
4. Got the Board to vote
5. Contacted the chairs and vice chairs of the 3 BLCs and let them know that they have the green light to get started on their work.

A Message from the President – 90 Day Progress Report (continued)

By Jean-Louis Briaud

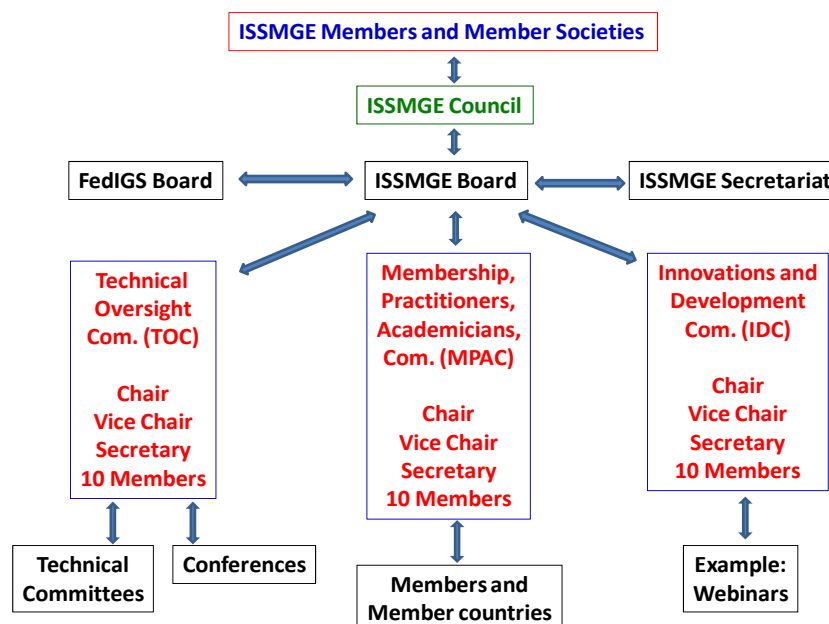

I am very happy to report that the Board voted unanimously to create the 3 new BLCs and approved the inaugural chairs, vice chairs, and special leaders of the 3 BLCs. This was done in our first ever conference call board meeting on 26 November 2009. It required some sacrifice from some of us as the call was at 5 am for me in the USA and at midnight for Michael Davies in New Zealand. This conference call was made possible by the wonderful help of Neil Taylor and Paloma Peers who managed to solve a tough problem efficiently. The three Board Level Committees are:

Technical Oversight Committee (TOC):

Chair: Suzanne Lacasse, Co-Chair: Kjell Karlsruud, Vice-Chair: Mike Jamiolkowski. The suggested charge of the TOC is:

- Oversight of the Technical Committees (TC) (decisions on the TC chairs, the TC core members, the TC members, the terms of reference, yearly evaluation). Each Technical Committee will be assigned a liaison on the TOC. The TOC liaison will keep in close contact with the chair of the assigned TC and help the TC perform well if necessary.
- Create and select the recipient for a Best Technical Committee award. This award will be given yearly. The award will consist of a certificate which will be distributed to all members of that TC.
- Oversight of the ISSMGE conferences. In this task, the TOC will work closely with the Chair of each conference to ensure that the highest quality is achieved. A TOC liaison member will be assigned to each ISSMGE conference. A serious effort will be made to involve the TCs in the program of the conference (e.g.: session titles in the conference program will have the TC name next to the title that contributed to the session topic and to the selection of speakers).
- Oversight of continuing education activities. These Continuing Education (CE) activities will include the in person short courses or international seminars, webinars, and videos. Interaction between TOC and the member societies will take place to identify the topics requested.
- Any other oversight effort which deals with the technical activities of ISSMGE.

Membership, Practitioners, Academicians Committee (MPAC):

Chair: Harry Poulos, Vice-Chair: Luiz DeMello. The suggested charge of the MPAC is:

A Message from the President – 90 Day Progress Report (continued)

By Jean-Louis Briaud

- a. Membership drive to increase the number of Corporate Members of ISSMGE. This membership drive should start by asking corporate members what they want out of ISSMGE, and then by providing the service requested as long as it is commensurate with the membership fee.
- b. Raise funds for the new ISSMGE Foundation and develop guidelines for member countries to apply for funds from the ISSMGE Foundation.
- c. Membership drive to increase the number of member societies. This task is truly the responsibility of the Regional Vice Presidents but the MPAC will work closely with them to exchange ideas on how to increase membership.
- d. Interaction with member societies to help them with membership problems.
- e. Interaction with individual members, in particular practitioner members, to help them with membership problems.
- f. Create and select the recipients for the Member Society Recognition Award and the Individual Member Recognition Award. This award will be given yearly. The award will consist of a certificate which will be given to the president of the Member Society and to the individual member.

Innovation and Development Committee (IDC):

Chair: Dimitris Zekkos, Vice-Chair: Charles Ng, Coordinator: Marc Ballouz. The suggested charge for IDC is:

- a. Develop innovations to better serve our members and to increase the impact and influence of ISSMGE and the Geotechnical Engineer in the world.
- b. Develop ways to enhance the value of the web site as a technical resource worldwide.
- c. Develop ways for individual members to communicate with each other in a very easy fashion.
- d. Initiate the webinar series
- e. Create and select the recipient for a best innovator of the year award. This award will be given yearly. The award will consist of a certificate which will be given to the ISSMGE member receiving the award.
- f. Strengthen and bring to a steady state the International Journal on Geoengineering Case Histories. Cooperation with the Technical Oversight Committee (TOC) and more generally all the Technical Committees (TC) is expected.
- g. Develop the lexicon into an electronic tool available on the web site

The three committees now officially exist. The leaders of these committees are in the process of selecting the members of their committee and making plans for action.

Students and Young Members Presidential Group (SYMPPG):

Chair: Jean-Louis Briaud, Vice Chair: Jennifer Nicks.

Another initiative that the ISSMGE Board and I have undertaken is the Student and Young Members Presidential Group (SYMPPG). I asked the 6 Vice Presidents to select 3 students or young members from their region to become members of SYMPPG. After collecting the nominations and applications, the 6 Vice Presidents selected their 3 SYMPPG members. They gave me their list of three but added that it was a shame of having to turn down other candidates. So I have decided to create two categories of SYMPPG members: the members per say and the corresponding members. The 18 (3x6) members of SYMPPG will be the ones who will attend the conference call meeting and vote when needed. The corresponding members will be those who were candidates but were not selected; they will receive the news about the SYMPPG, will be able to participate by email but will not be attending the conference call meetings and will not vote. If a member does not contribute, he or she will be replaced by a corresponding member who has shown definite interest and has contributed. I have also decided to enlarge the corresponding member list by including a few other young members from your national society. If you wish to have a corresponding member on the SYMPPG please send me their CV, contact information, and a one page statement written by the young member indicating why they are interested in contributing to SYMPPG.

A Message from the President – 90 Day Progress Report (continued)

By Jean-Louis Briaud

The goal of SYMPG is for ISSMGE to listen to the wishes of the younger (less than 35 years old) geotechnical engineers on what ISSMGE can do to be more attractive to the next generation by letting them interact directly with the President. I am excited about working with this worldwide group of young people who will no doubt have a lot of energy and a lot of ideas for all of us. If you wish to know who are the members and corresponding members of SYMPG, let me know and I will send you the list.

ISSMGE Foundation

I have also been working on the creation of the ISSMGE Foundation; here are some tentative guidelines. The Foundation is created to provide financial help to geotechnical engineers throughout the world who wish to further their geotechnical engineering knowledge and enhance their practice through various activities which they could not otherwise afford. These activities include for example attending conferences, participating in continuing education events, purchasing geotechnical reference books and manuals. Funding for the ISSMGE Foundation will come from donations from companies and individuals who care about the well being of less fortunate geotechnical engineers in the world. The funding levels will be

1. Diamond: \$50,000 and above
2. Platinum: \$25,000 to \$49,999
3. Gold: \$10,000 to \$24,999
4. Silver: \$1000 to \$9,999
5. Bronze: \$0 to \$999

The names of the donors will be recognized with the corresponding levels on the ISSMGE web site under the page dedicated to the ISSMGE Foundation, in the ISSMGE Bulletin on the page dedicated to the ISSMGE Foundation, and at the International Conferences on Soil Mechanics and Geotechnical Engineering. Neil Taylor has been working hard in finding a good way to set up such an endeavor for the best use of the money that I am raising. I have already collected a number of commitments and need your help to raise more money. **If it is within your means, please help me in this task and contribute to the ISSMGE Foundation; contact me and I will tell you more about it and how it works.**

Acknowledgements

I want to thank all the people that have made this work possible including the Secretary General, the Members of the Board, the Leaders of the Board Level Committees, and many of you for contributing to our continuous improvement by organizing conferences, leading Technical Committees, and other activities. If we can mobilize our 18,000 plus members to contribute even a little bit we can move mountains.

As usual, feel free to communicate with me on what is important to you. My contact information is on my web site at <https://ceprofs.civil.tamu.edu/briaud/>.

Take care, do good work, and be safe.



Views of Young Geotechnical Engineers

Young Member Award winner: Anders Kullingsjö, Sweden



Personal history:

Born: 01 January 1974

-1997, Chalmers University of Technology, Gothenburg. Master of Science – Civil Engineering.

-2007, Chalmers University of Technology, Gothenburg, Doctor of Technology. Department of Civil and Environmental Engineering, Division of GeoEngineering Geotechnical Engineering

Experience Record:

1998-2005 Skanska Teknik AB: Consultant Geot. Eng.

2005-2009 Skanska Sverige AB: Manager Geot. Eng.

Present position:

Senior Manager / Specialist at Geot. Eng.

Commission of trust:

- Swedish Geotechnical Society, secretary in the west division 1999-2003 and member in the election committee 2003-2006

- Implementation committee of the Eurocodes in Sweden, Member of the steering committee 2005 to date

- Representing Sweden in ISSMGE Technical committee "Limit State Design in Geotechnical Engineering", TC23. 2006 to date

Receiving this award is a great honour for me and an acknowledgement of that the long tradition of geotechnical engineering in Sweden still is in the forefront.

My research presented in my thesis (Kullingsjö, 2007) and in the article nominated to the YMA award, presented in the 17th ISSMGE Conference (Kullingsjö, 2009), deals with the deep excavations in soft clay and how the excavation will affect the immediate surroundings in terms of deformation. The uniqueness of my work is the close cooperation between academia and industry and that an exchange with outstanding universities in some areas made it possible to use highly advanced numerical analysis at a real case in the centre of Gothenburg. The research was divided into Class A predictions of a real case, field monitoring, laboratory testing, calibration of advanced constitutive soil models and Class B calculations with more or less advanced constitutive models. The abstract from the nominated article is presented below:

When excavating in an urban environment, evaluation of the magnitude and distribution of ground movements is an important part of the design process, since excessive movement can damage adjacent buildings and utilities. In order to minimize the movement of the surrounding soil, a retaining wall support system is used to provide lateral support.

This article is a brief summary of the dissertation "Effects of Deep Excavations in Soft Clay on the Immediate Surroundings: Analysis of the Possibility to Predict Deformations and Reactions Against the Retaining System" presented at Chalmers in 2007, (Kullingsjö, 2007). The dissertation describes different methods for the evaluation of ground movements adjacent to a deep excavation in soft clay as well as how to estimate the lateral earth pressure that acts on the retaining system. It presents a review of:

- Soil characteristics of importance for the evaluation of deformations and earth pressure.

- Current empirical methods for estimating ground surface settlements.

- Different classical methods for calculating lateral earth pressure.

- Various soil modelling methods, with focus on the theory of elasto-plasticity.

The review is followed by an extensive case study performed at the Göta tunnel project in the centre of Gothenburg, Sweden.

Back analyses were performed in order to predict and interpret ground deformations and the development of stress changes against the retaining wall system. These analyses took the form of non-linear finite element analyses with three different constitutive models (an isotropic linear elastic Mohr-Coulomb model, the e-ADP, which is a total stress based model capable of modelling anisotropic undrained shear strength as well as non-linearity in shear, and MIT-S1, a bounding surface model based on effective stresses). The different outcomes of these three models are compared and discussed. Special focus has been placed on evaluating the parameters of the MIT-S1 model and its response compared to advanced laboratory tests.

ACKNOWLEDGEMENT

The work has been carried out at the Division of GeoEngineering, Department of Civil and Environmental Engineering at Chalmers University of Technology, with financial support from Skanska, the Swedish National Road Administration, SBUF and the VBT consortium (an industrial consortium financed by Vinnova, SBUF, the universities and the companies where the project took place). The project was made possible thanks to an agreement about openness and cooperation between the Builder, the Contractor and the University regarding working sequences and field measurements at the J2 construction site, which was a part of the Göta tunnel project in Gothenburg. Extensive field monitoring and laboratory testings were made possible as a result of this agreement and financial support. Exchanges and cooperation with other universities, MIT (US), Imperial College (UK) and NTNU (Norway) were a very valuable part of the project.

REFERENCES

Kullingsjö, A. (2007). *Effects of Deep Excavations in Soft Clay on the Immediate Surroundings: Analysis of the Possibility to Predict Deformations and Reactions Against the Retaining System, Chalmers University of Technology*: 334 pp.

Kullingsjö, A. (2009). *Effects of deep excavations in soft clay on the immediate surroundings*. Proc. of 17th International Conference on Soil Mechanics and Geotechnical Engineering, Alexandria, Egypt: 1923-1930.

Views of Young Geotechnical Engineers

Young Member Award winner: Leon van Paassen, The Netherlands



Personal history:

Born: 28 January 1976

Education:

- 2002, Delft University of Technology, MSc – Mining Engineering, Engineering Geology.

-2009, Delft University of Technology, PhD – Applied Sciences, Environmental Biotechnology

Experience Record:

2000-2002, IFCO Foundation Expertise BV – Junior Geotechnical Engineer

2002-2005, GeoDelft – Advisor Foundations and Underground Constructions.

2005-2009, GeoDelft/Deltares – R&D Smartsoils®.

2009-now, Delft University of Technology, Department of Geotechnology – Assistant Professor Geo-Engineering.

Committees

2003-2007 Treasurer Ingeokring (Dutch department IAEG/ISRM)

2008 Organising committee for 1st International Conference on BioGeoCivil Engineering

2009-now, Editorial board Ingeokring Newsletter

It is a great honour for me to receive the Young Member Award 2009 for my publication “Scale up of BioGrout, a biological ground reinforcement method”, which I presented during the 17th ICSMGE in Alexandria, 5-9 October 2009. In this paper I describe the experiments that were performed to develop BioGrout – a new ground improvement method based on microbially induced carbonate precipitation – from proof of principle in the laboratory to a field scale experiment, in which equipment, conditions and techniques were applied, which are also used in emphasized applications, such as increasing the stiffness of railroad embankments. First, experiments were performed in a 1 m³ container set-up simulating a spherical injection from a single point, followed by a 100 m³ field scale experiment. In this final experiment 40 m³ of sand was biologically cemented within 12 days and 6 flushes, stretching over a distance of 5 m between three injection and three extraction points. In both scale up experiments significant increase of the average strength was obtained, but distinct spatial variability of the mechanical properties was observed. The heterogeneity is considered to be affected by the induced flow field, the distribution of bacteria, the procedure of supplying reagents (continuous flow or sequential batches) and the crystallization process.

The experiments were part of a research project performed by Deltares, Delft University of Technology and Volker Staal en Funderingen from The Netherlands in collaboration with Soletanche Bachy in France and Murdoch University in Australia and funded by SenterNovem (Dutch Ministry of Economic Affairs). The paper formed a chapter of my PhD thesis, which I defended 20 October 2009.

In my current position as Assistant Professor Geo-Engineering at Delft University of Technology I plan to continue my research in the interdisciplinary field of BioGeoCivil Engineering and develop new ideas based on sustainable concepts found in nature that solve engineering challenges such as resource depletion and reducing the impact on the environment. I aim to embed my research in the geotechnical engineering society by joining the TC 17 on ground improvement and initiate a working group within this on biomediated ground improvement. As I am active at the interface between biogeochemistry and engineering encountering a wide range of materials varying from soft soils to hard rocks it is evident that I support all efforts towards further collaboration between the three sister societies ISSMGE, IAEG and ISRM, through the FedIGS initiative. I hope that in future the boundaries between these closely related disciplines of rock mechanics, soil mechanics, geotechnical engineering, environmental engineering and engineering geology will further disintegrate, as it is mainly due to these cross disciplinary discussions that new ideas are discovered. As a future lecturer I expect to share my enthusiasm about the challenging field of Geo-Engineering and stimulate the young students to actively participate in these international societies e.g. by joining the YGEC or other international conferences in order to exchange their ideas, views and cultures with their fellow students and colleagues from abroad.

Views of Young Geotechnical Engineers

Young Member Award winner: Susumu Nakajima, Japan

**Personal history:**

Born: 26 April 1978

Education:

- 2000, Tokyo University of Agriculture and Technology
- 2005, University of Tokyo, Master of Engineering
- 2008, University of Tokyo, Doctor of Engineering

Experience Record:

2003-2007; HONMA Corporation, Japan
2008; Researcher, Public Works Research Institute, Japan

It is pleasant surprising and honor for me to be given an opportunity to introduce my research and my views of the international society, future of geotechnical engineering in the ISSMGE Bulletin.

The paper submitted to the ICSMGE2009 was on the effect of shaking history and material properties of geogrid models on the seismic behavior of the gravity type and geosynthetics reinforced soil retaining walls, which was the part of 14-years research achievements conducted by University of Tokyo, Railway Technical Research Institute and Tokyo University of Science, Japan. This research project started at 1995 immediately after the Hyogoken-Nanbu earthquake so as to avoid the catastrophic failure of the retaining structures observed in the earthquake.

This research began with the studies on the difference between the pseudo-static and dynamic behaviors of retaining walls. Next we conducted the shaking table model tests on the conventional and geosynthetics reinforced soil retaining walls so as to investigate into seismic earth pressure and failure plane formation in the backfill layers of the retaining walls. Based on the knowledge obtained from the senior colleague's achievements, I have attempted to develop a displacement prediction method of the retaining walls with considering the effects of subsoil and backfill deformation. In the development of the displacement prediction method and its application to the simulation of the previously conducted shaking table model tests, I had the interests on the effect of shaking history on the seismic behaviors of the retaining structures because most of our model tests were conducted with the step wise shaking. Abstract of the paper submitted to the ICSMGE2009 is as follows. If you have any interests please read it and discussion is every time welcome for me (s-nakaji55@pwri.go.jp).

A series of shaking table model tests on gravity type and reinforced soil retaining wall models was carried out so as to investigate into seismic behavior of retaining walls. In this study, seismic behaviors obtained from the step by step shaking tests were compared with the ones from the tests in which the models were subjected to large amplitude shaking from the beginning (i.e. no effects of the shaking history on seismic behavior). The test results revealed that the shaking histories had a significant effect on the seismic performance of the gravity type retaining walls, while it was not the case for the reinforced soil retaining walls. The former behavior is possibly affected by occurrence of local bearing capacity failure beneath the retaining walls. Effects of material properties of geogrid models (i.e. pullout resistance, rupture strength and tensile rigidity) on seismic performance of the reinforced soil retaining wall were also investigated in this study by using two different types of geogrid models. Even though the material properties of the geogrid models were largely different, seismic performances of the retaining walls were almost equal to each other. This behavior can be explained by considering the difference in the pullout rigidity between the two geogrid models which is not taken into account in the current design procedure.

I need to answer the request to mention my views of the international society and future of geotechnical engineering. First, the ISSMGE gives us the chances to interchange the information and knowledge by organizing many international symposiums and conferences in spite of the difficulty for managing them. These chances are highly valuable for both researchers and engineers while I personally felt that in the recent international and regional conference, the chances to have the presentations and discussions are reducing. This may be partially because of the enlargement of the ISSMGE, which is one of the achievement, but the chances to be given the constructive comments from the senior researchers and engineers in different countries and discussions are highly valuable for further works. Therefore, I am expecting the ISSMGE to manage this tendency although I understand that the organizing is quite difficult.

Lastly, I think that responsibility of the geotechnical engineering for the society is becoming more important as compared with several tens of years ago, but thanks to the ISSMGE's effort, the cooperative work and integration of the knowledge is also becoming possible. So, I believe that geotechnical engineering continue to contribute to the society in many situations. And I personally feel that I need to learn more from the seniors so as to be a member to contribute the geotechnical engineering.

Reminiscences

Professor Milton Vargas

Life and work of the most important living Brazilian geotechnical engineer

Interviewer: Mr. Helvio Falleiros, journalist of Brazilian Society for Soil Mechanics and Geotechnical Engineering



Academic titles: Electrical Engineer, Sao Paulo University, 1938; Civil Engineer, Sao Paulo University, 1942; Special Student, Harvard University, 1946; Emeritus Professor, Sao Paulo University Polytechnic School, 1988.

Career: IPT – Researcher at State of Sao Paulo Technological Research Institute - (1938-1952), Member of Research Council - IPT (1952-1987), and President IPT (1987).

Founder of THEMAG Engenharia Ltda, in 1961.

Publications: more than 140 papers on soil mechanics, foundations, earth dams, etc.

Milton Vargas smiles in a reserved way when he starts to tell his story. He is ninety five years old. He dedicated his life to Engineering. This vocation started to show up when he was a kid, because the boy grew up surrounded by engineering civil works, following his family. By that time, one of the plays he liked most was building dams. Later, he was one of the first to study Brazilian residual soils. He believes in the Chinese proverb: “knowledge comes from the hands”. Milton Vargas introduced his country’s

soil to the most important name of international geotechnical engineering – Karl von Terzaghi. In almost a century of life, Vargas developed three passions – Engineering, Philosophy and Literature. But when someone asks which one is the most important to him, he does not hesitate: “Engineering, I have no doubt”.

IPT (State of Sao Paulo Technological Research Institute) was something very important in your life, wasn’t it? Can you talk a bit about it?

I started my career at IPT, in 1938, when I was 24. By that time, I was completing studying Electrical Engineering at Sao Paulo Polytechnic School. My first position was at the Foundations and Soils Session of the Institute. I went there because they organized a geophysics team. I studied electrical engineering, so I knew about electrical phenomenon.

Did you have any challenge or contribution at IPT?

Well, once my boss asked me to sound the ground. After that, I published an article about this technique being used in civil engineering works, as it was only used in mining jobs.

How did you choose electrical engineering?

My father, Abel Vargas, was a medical doctor and worked at Light and Power – electrical company. We used to live at dam’s sites and we were always close to the civil engineering works of the company. I have spent my childhood seeing dams and playing with sons of other engineers. We used to play building dams. I recall once adults come to destroy our dam because it was disturbing their job. It was indeed blocking their way, because it was well built. Growing up surrounded by engineers made me like them, rather than like my father, a physician.

You also studied civil engineering...

Yes. I graduated in 1942 from the same engineering school. I was still working at IPT.

You studied in Harvard University. What took you there?

It happened in 1946. I always had a scientific curiosity and a strong will to know Brazilian soils. The characteristics presented in studies and techniques did not correspond to the reality. So I decided to go to Harvard University, which was the main soil mechanics school at that time. By the way, professors Karl von Terzaghi and Arthur Casagrande were there, and were the two most important names in soil mechanics then.

I did not arrive there with empty hands, however. I took along me the experience I gained when doing research with tropical soils, at IPT. As a result of researchs in Brazil and at Harvard, it was possible to explain the differences between tropical soils, in Brazil, and sedimentary soil, elsewhere.

However during classes I did not hear about tropical soils. They only talked about sedimentary soils, which was what people knew about then. They were very interested in Boston’s clay and I knew Brazilian soils were different.

Reminiscences

Professor Milton Vargas

Life and work of the most important living Brazilian geotechnical engineer (continued)

I consider this a very important experience to me. Everything I know about soils I owe to them at Harvard. Terzaghi was an excellent professor, but I owe even more to Casagrande, the best teacher I ever had.

What happened when you came back to Brazil?

Terzaghi came along with me to learn about residual tropical soils. He visited Consolação street's civil works, in São Paulo. His face's expression showed he was seeing something new for the first time. When I talked about peculiarities of these soils during his classes, Terzaghi used to show interest. But when he touched this soil for the first time, his face was more expressive than any verbal commentary. He was astonished.

You also took part in the foundation of ABMS (The Brazilian Society for Soil Mechanics and Geotechnical Engineering), wasn't it?

Yes. We had the idea of joining all Brazilian professionals acting in geotechnical engineering. We wanted to make the geotechnical engineering something official. That is why me and some engineers from Rio de Janeiro and Rio Grande do Sul, created the Brazilian Society for Soil Mechanics and Geotechnical Engineering, ABMS.

Antônio Costa Nunes, Antônio Nápoles Neto, Casemiro J. Munarski, Francisco Pacheco Silva, and I used to discuss little and work a lot. So ABMS was born, on July 21th, 1950. And I also had the honor of being the entity's first president, between 1950 and 1952.

When did you start giving classes?

In 1952 I stopped working at IPT and started my career as a teacher, at São Paulo University's Polytechnic School. It was really hard, but it was worthy. Teaching is really worthwhile.

Tell me about THEMAG (a Brazilian consulting company in civil engineering)?

Well, I always say I was convoked to integrate, with other four engineers, a company which joined technical capacity to project big civil works. The call together came from CELUSA (Urubupungá Electrical Centrals) and the reason was to develop Brazilian engineering projects and to build Brazil's hydroelectric power plants. At that time, the important project was the construction of Urubupungá and Ilha Solteira dams. I accepted the challenge and, together with Telemaco Van Langendonck, Henrique Herweg, Yves Eugene Josquin and Alberto Giaroli we created Themag Engineering. Souza Dias, CELUSA's principal engineer, did not want to hire foreign engineers. He said that if he had only Brazilian engineers, he would have them 100% focused on that project.

You wrote many technical articles. How was it?

The first one was "Soil Exploration to Study Foundations", published by Polytechnic Magazine, in 1948. In the next year, the same magazine published "Vertical Sand Drains' Theory". In 1950, this magazine brought "Observations about São Paulo Buildings Settlements". My post graduate thesis at the Polytechnic School was "Strength and Compressibility of Residual Clays". In the next year, I took part of the 3rd International Conference on Soil Mechanics and Foundation Engineering, in Zurich, Swiss, where I presented "Some Properties of Residual Clayey Soils of Southern Brazil".

Another passion you have is the Philosophy, isn't it? Have you also published articles on this subject?

Yes. In 1997, the Brazilian Magazine of Philosophy published "History of Nature's Mathematization". About Philosophy I also wrote a book, titled "Towards a Philosophy of Technology".

But you also wrote other books, didn't you?

Yes, I wrote "The History of Science and Technology in Brazil". By this time I was in charge of classes on Philosophy and Science Evolution, at São Paulo University's Polytechnic School. "Truth and Science" was published in 1981. And "Introduction to Soil Mechanics", which gave me Jabuti and Roberto Simonsen prizes, in 1978, what have made me very proud.

Reminiscences

Professor Milton Vargas

Life and work of the most important living Brazilian geotechnical engineer (continued)

Was at this time that you participated in the foundation of the Brazilian Philosophy Institute?

No. The Institute came earlier, in 1951.

And the articles at Folha de S. Paulo (Sao Paulo city newspaper)?

These were published regularly between 1976 and 1984.

And what was it, exactly?

It was about one hundred chronicles on socioeconomical aspects of Brazil and philosophic reflections on Latin America.

Tell me about the literature?

Well, in 1989 I was elected to the State of Sao Paulo Literary Society. It was when I published "Poetry and Truth".

Six books, 140 articles, nine prizes, tens of civil engineering works. Ninety five years old. Almost a century dedicated to three passions – Engineering, Philosophy and Literature. But when someone asks which one is the most important to him, he does not hesitate: "Engineering, I have no doubt. I'm an engineer, before anything else".

Milton's answer is given with a sort of shy smile. The smile of somebody that accomplished much more than proposed. More than understanding his country's soil, Vargas spread this knowledge beyond Brazilian territory. When he reveals his history, Vargas also reveals Brazilian Soil Mechanics history with a grin.

Case History

Concepts on CFRDs Leakage Control - Cases and Current Experiences

Manoel S. Freitas Jr. – Consulting Engineer
hydrogeoeng@uol.com.br

1. Introduction

Concrete Face Rockfill Dams (CFRDs) technique has been extensively used especially in 80s and 90s in design and construction of several rockfill dam structures with heights ranging from 140 to 190m, such as: Foz do Areia (Brazil, 160 m), Xingó (Brazil, 145m), Aguamilpa (Mexico, 187m) and Segredo (Brazil, 145m). This tendency has been effectively followed in the last decade too for some other iconic projects like: Tianshengqiao 1-TSQ.1 (China, 178 m), Sanbanxi (China, 186 m), Hongjiadu (China, 192 m), Barra Grande (Brazil, 185 m), El Cajón (Mexico, 188 m), Kárahnjúkar (Iceland, 190m), Bakun (Malaysia, 205m), Campos Novos (Brazil, 202m) and Shuibuya (China, 233m) the tallest CFRD structure ever made. Mazar (Ecuador, 166 m), Porco III (Colombia, 160m) and La Yesca (Mexico, 210 m) and Jiangpinghe (China 219m) - still under construction - are equally excellent examples of CFRDs progress and use. However, during the 90s decade, some crack events occurred in several CFRDs, such as: Xingó, Aguamilpa, Itá and Itapebi (Brazil), and the dam leakage reached up to 1000 to 1800 l/s (Itapebi and Ita CFRDs). Remedial slab treatments have been implemented and leakage flow rates dropped below 200 l/s during operation period. More recently, several unpredicted slab ruptures occurred in Tianshengqiao 1 (2003 and 2004) during reservoir operation, and Campos Novos and Barra Grande in 2005, as well as in Mohale in 2006 during first reservoir impounding. In these CFRDs, due to the slab horizontal stresses, a sudden concrete spalling rupture along vertical joints at slab center areas was followed by significant dam leakages of around or higher than 1000 l/s in Campos Novos and Barra Grande and 600 l/s in Mohale. Currently and mainly for CFRDs with heights > 190 m, rockfill zoning, compaction procedure control and changes of the perimeter and vertical joints design for slab strain control have been implemented. However, tall CFRDs structures (heights > 250 m) face new dam behavior challenges and cracking control during impounding.

2. Rockfill Zoning

CFRDs zoning designations is one of the most important concepts (Cooke and Sherard 1987). They clearly define the functions and requirements of each zone of the embankment and allow the exchange of information between CFRDs designers and constructors. These zoning concepts are still present in the large majority of the dams. Figure 1 reproduced from Cooke and Sherard (1987) show the original zoning designations.

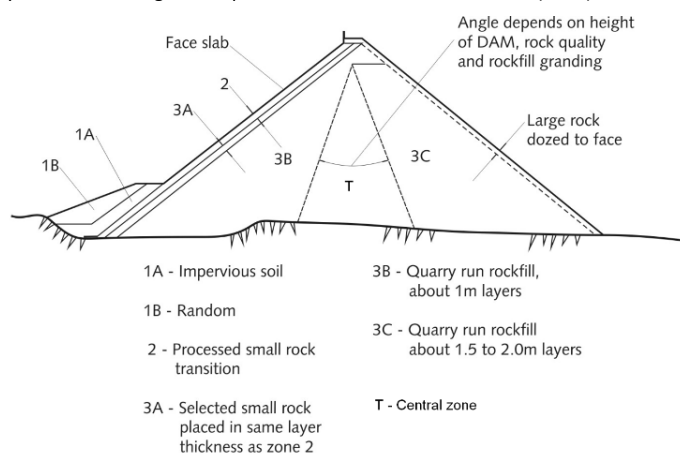

Figure 1 Zone designations for CFRD of Sound Rockfill (Cooke and Sherard, 1987)

“Zone 1 – A compacted blanket impervious soil” was placed on the lower part of the concrete face at Alto Anchicaya Dam (1974). This detail has since been repeated on the Areia, Khao Laem, and Golillas Dams and in several other tall dams. The purpose is to cover the perimeter joint and slab in the lower elevations with impervious soil, preferably silt, which would seal any cracks or joint openings. In addition, dams without this upstream Zone 1, have been completely successful.

“Zone 2 – Such select grading of Zone 2 provides a semi-impervious barrier, preventing any large leakage, even if a leakage path develops through a crack in the concrete slab or a defective water-stop. Crusher-run minus-15-7.5 cm rock fill has been used”. The semi-pervious property is of value near the perimeter joint, and to an elevation where flood retention during diversion could rise, before the placement of the concrete face. The early and primary purpose of the thin zone of finer rock directly under the slab (cushion zone) was to provide uniform and firm support for the concrete slab.

Case History

Concepts on CFRDs Leakage Control - Cases and Current Experiences *(continued)*

An important and revolutionary construction procedure was introduced at Itá CFRD (1999) by the main civil constructor (Resende, Materón, 2000). An extruded concrete wall built as support for the concrete face replaced all the troublesome operations like compaction along the slope of zone 2 and eliminates the asphalt emulsion or the shotcrete spray. Benefits of this curb, nominated by Cooke like “The Itá Method” and from 1999 on has been adopted in all CFRDs already constructed in the World. Figures 2a and b, show the curb details and curb extruding machine.

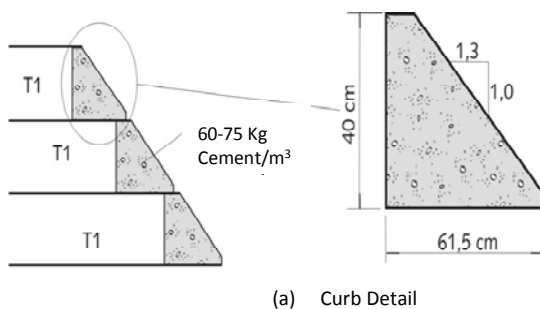

Figure 2: The “Itá Method” (Resende, Materón , 2000)

Figures 3, 4, 5, and 6, present for Campos Novos, Tianshengqiao 1, El Cajón and Shuibuya, respectively, maximum cross section zoning, and upstream view , as well.

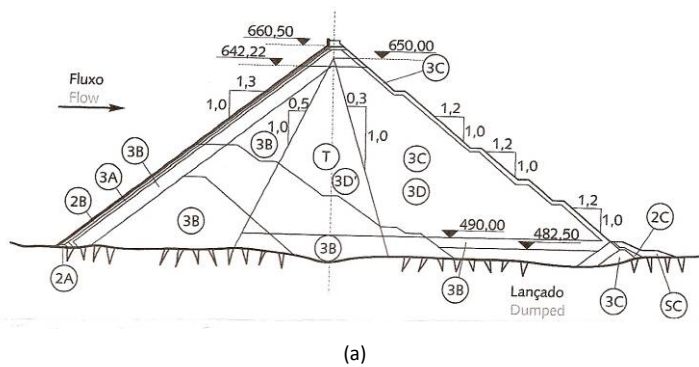

Figure 3: Campos Novos : cross section – (a) (Courtesy of Oficina de Textos, Editor) and (b) upstream view in the end of construction

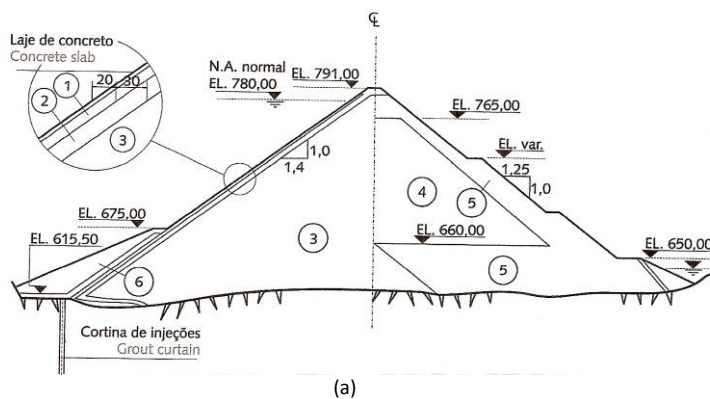

Figure 4: Tianshengqiao 1 (TSQ.10 : cross section – (a) (Courtesy of Oficina de Textos, Editor) and (b) upstream view in the end of construction (2000)

Case History

Concepts on CFRDs Leakage Control - Cases and Current Experiences (continued)

Good correlations have been obtained between geomechanical classification of the rock foundation and the required gradient to be applied to prevent the erosion of the plinth (Cruz, Materón, Freitas, 2008). Plinth structure is usually on “hard, nonerodible fresh rock which is groutable. For less favorable foundation rock, after a trench is made to an estimated acceptable foundation, many methods are available to treat local imperfections. The criterion is to eliminate the possibility of erosion or piping in the foundation. Careful excavation is used to minimize fracturing of the rock surface on which the toe slab is placed. Air or air-water cleanup, just prior to placing concrete, is required to obtain a bonded contact of the concrete to the foundation.” (Cooke, Sherard, 1987)

Since 1970's, the main factors that caused perimeter joint movements and potentially intense dam leakage were: rockfill differential settlements from construction stages, rock type (upstream and downstream shells), plinth abrupt geometry foundation (at abutment areas) and valley geometry.

Perimeter joint design evolution has progressed from the “simple concept” - one central rubber waterstop and/ or bottom copper backed by a concrete pad, Cethana Dam- 1971, to a “double or multiple defense concept”, as Alto Anchicaya Dam -1974, with two waterstops, one made of copper (bottom) and a center one made of PVC, and a mastic cover. Foz do Areia, Segredo and Xingó CFRDs followed similar concept. However, Segredo and Xingó have eliminated the center waterstop to ensure a better concrete quality. A sand-asphalt pad and a filter material ($\phi_{max} = 1 \frac{1}{2}$ ") under the slab as a safe and leakage control feature, have been designed as an additional defense line, as an international proceedings issue.

An earthfill blanket at upstream deepest sections in river bed at plinth and slab lower areas has been built as an international practice, and an additional protection in case of cracking issue.

Pinto and Mori (1988) presented a new defense concept, using a “dirty fine sand” over the perimeter joint. Segredo (1993) and Xingó (1994) have been designed with a “fine sand layer” over the perimetric joint as an additional protection (“clogging effect”), in case of the damage of the mastic. Aguamilpa (1993) and Tianshengqiao 1 (2000), besides double waterstops placement, a fly ash material protected by a geotextile wrap and a metallic plate (perforated) completed the perimeter joint design (Figure 4, b). In EL Cajon (2006) a multiple defense concept, similar as designed for Aguamilpa and Tianshengqiao 1, was adopted and complemented by a addition of copper waterstop at joint upper part.

Table 1 : CFRDs Features

Dam (country)	Complection Year	Rock type	Dam max. Height H (m)	Valley Shape Factor - A/H ²	Settlement Max. (m)	Settlement Max. / dam max. height (%)
Alto Anchicayá (Colombia)	1974	Hornfels -Diorite	140	1.1	0.77	0.55
Foz do Areia (Brazil)	1980	Basalt/Basaltic breccia	160	5.4	3.52	2.20
Aguamilpa (Mexico)	1993	Gravel/Rockfill	187	3.9	1.70	0.90
Segredo (Brazil)	1993	Basalt/Basaltic breccia	140	4.4	2.23	1.59
Xingó (Brazil)	1994	Granite-Gneiss	140	6.9	2.90	2.07
Itá (Brazil)	2000	Basalt	125	7.0	1.30	1.04
TSQ.1 (China)	2000	Limestone/Mudstone	178	5.7	3.32	1.87
Machadinho (Brazil)	2002	Basalt	125	6.0	1.60	1.28
Barra Grande (Brazil)	2005	Basalt	185	3.0	3.40	1.84
Campos Novos (Brazil)	2005	Basalt	202	2.6	3.10	1.53
El Cajón (Mexico)	2006	Ignimbrita	188	3.2	0.85	0.45
Mohale (Lesotho)	2006	Basalt	145	3.6	2.86	1.97
Kárahjúkar (Iceland)	2007	Basalt	190	2.7	1.53	0.81
Shuibuya (China)	2008	Limestone / Mudstone	233	2.6	2.47	1.06
Bakun (Sarawak – Malaysia)	2008*	Greywacke/shale /mudstone	205	3.0	2.28 *	1.37
Mazar (Ecuador)	2009*	Quartzitic schists	166	1.7	1.28*	0.77

(*) end of construction

Case History

Concepts on CFRDs Leakage Control - Cases and Current Experiences

(continued)

In China, rubber sealing materials have been used as “GB” and “SR” replacing the “IGAS” material (Guocheng and Keming, 2000). GB filler material combined with a corrugated GB rubber joint, (Figure 7) designed and manufactured by China Institute of Water Resources and Hydropower Research (IWHR), Beijing, were applied in Shuibuya, Bakun and currently Mazar CFRD (166 m, under construction), (Cruz, Bayardo, Freitas, 2009).

For CFRDs structures higher than 200m such as Shuibuya, 233m (2008), Bakun, 205m (2008), Campos Novos, 202m, (2005), a perimeter joint “multiple defense concept” has been successfully designed and implemented.

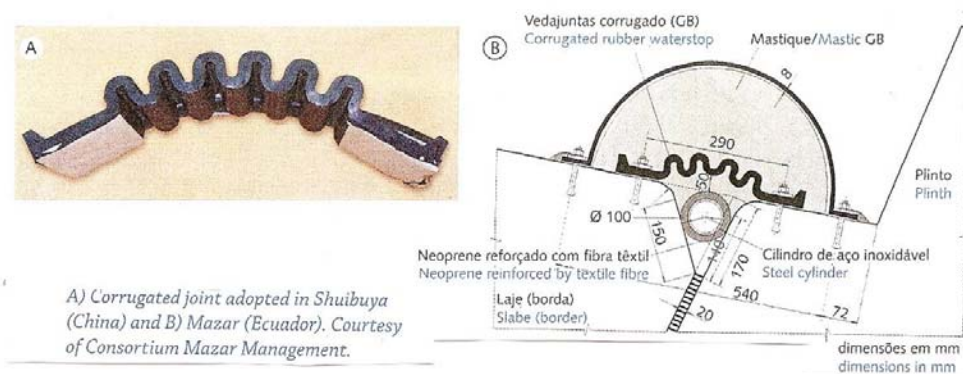

Figure 7– Corrugated Joint adopted in Shuibuya (China), Bakun (Malaysia) and Mazar (Ecuador)
Cruz, Materon, Freitas , 2009 (Courtesy of OFICINA DE TEXTOS, Editor)

Reinforcing bars placed in plinth (perimeter joint) and in the face slab seek to reduce concrete shrinkage, and to minimize cracks developed from bending strains imposed mainly during reservoir impounding. Two layers of longitudinal steel have sometimes been used in the past. Recently, it is generally accepted that a single layer should be used. The steel is put 10 - 15 cm clear of the upper surface as temperature steel, where it is hooked by the anchors: 0,3% each way appears adequate. The purpose of the anchors is simply to pin the concrete to the rock. The anchors are not to resist any given uplift loads.

Plinth construction progress continually in sections (each 50 to 80m aprox.), with construction joints, without waterstops. The longitudinal reinforcement steel passing through the construction joint represents as a good practice solution (Cruz, Bayardo, Freitas, 2008). Construction joint green cutting joint treatments are used commonly before re-start concrete pouring.

4. Vertical and horizontal joints

4.1 Horizontal joints

Horizontal construction joints have been designed and constructed according to the face slab construction stages, 2 to 3, as an international practice. Horizontal joints treatment before next slab stage consist in removing some centimeters of the pre-existent concrete, surface cleaning with air or green cutting facilities to remove exposed aggregates. The reinforcement steel being continue is overlapping the next concrete pouring stage. Construction joint should not be considered as contraction joints, waterstops are not required as unnecessary and expensive according to good engineering practices.

4.2 Slab – plinth connection joints

Aiming to sealing protection (in case of cracks) improvement, at a “L” distance (often ranged from 10 to 20 m) from the plinth, an additional joint sealer (besides of the copper joint sealer at the slab bottom) has been installed in some CFRDs structures. In TSQ.1, an additional PVC joint sealer has been designed embedded along slabs vertical joints at a distance of L = 20m from the plinth.

In Barra Grande and Campos Novos CFRDs, a PVC cover has been designed over the slab vertical joint top at a distance L = 20m from the plinth. However, these sealing protection systems have often shown troubles during construction stages to keep a good concrete pouring in these restrict parts, besides difficulties in maintaining the alignment of the PVC joint during the slipping form works (Cruz, Bayardo, Freitas, 2009).

Drainage facilities at upstream lower areas during construction are mandatory to control and to protect against slabs uplift (bulging displacements) along perimeter joint due to relevant piezometric head pressures in rockfill river bed low parts at plinth areas.

4.3 Vertical joints

Vertical joints are “contraction joints” - between slabs, which means, no steel bars trespassing between slabs are required, - current international practice. Two different design concepts have been followed according to slab areas: at abutments (tension zones) and center part (compression zone). At abutment areas (tension zones), where joint openings are predicted, tension joint designs have progressed to a double defense concept as a common practice, a copper joint sealer installed at the slab bottom, and a second joint sealer (JEENE type, or PVC) on the joint top.

Case History

Concepts on CFRDs Leakage Control - Cases and Current Experiences (continued)

This practice has been adopted in several CFRDs, such as : Itá (1999), Itapebi (2002), Machadinho (2002), Campos Novos (2005) and Barra Grande (2005) (Figure 8 b).

Aguamilpa and Tianshengqiao 1 followed the similar concept, a double water stop (copper at bottom and a PVC at center part) and an additional fly ash (coal ash in case of TSQ.1) on the joint top, protected by a geotextile wrap and metallic perforated cover.

In Itá CFRD was introduced the extruded curb, for the first time, over the upstream slope (cushion zone) protection thus replacing the traditional compaction and asphalt coat protection alternative.

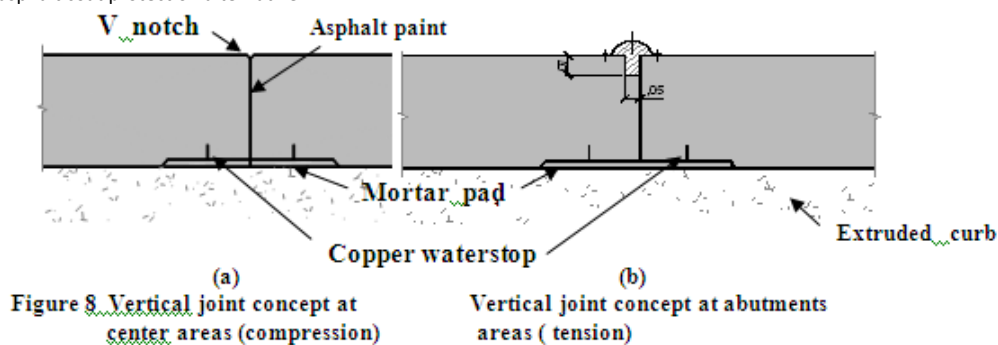

Slab Central areas (compression zones): vertical joints in center areas (compression zone) have been designed with a bottom copper joint only as standard solution (Figure 8a). In addition, a V- notch (10 x 10 mm) at upper part and an asphalt paint was applied along concrete joint. This practice was adopted until year 2005.

Cracking and concrete spalling phenomenon was initially recorded in Tianshengqiao 1 (2003, 2004), after three years of operation - Figures 9 and 10. Barra Grande - Figure 11, and Campos Novos (2005), Figure 12, and Mohale (2006), Figure 13, during the reservoir impounding, have recorded similar spalling issues. Slab horizontal compression strains due the combination of following dam features: dam height, low construction rockfill deformation modulus and valley shape (Pinto, N. , 2007), seem to give an explanation for this problem.

To mitigate this cracking phenomenon, a new vertical joint concept has been adopted, according to the following items: i) mortar pad imbedded into the curb extruded concrete (keeping the original slab thickness design); ii) flexible filler along vertical joint (wood, neoprene); iii) to reduce (maximum 2 mm) or eliminate the upper V notch; iv) anti-spalling reinforcement.

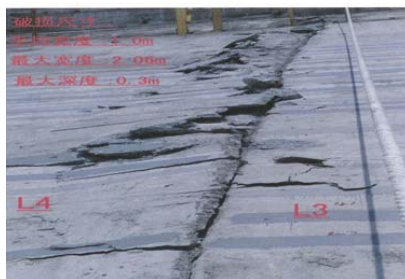

Figure 9 - Tianshengqiao 1 concrete spalling along Center slabs L3 and L4 (2003)

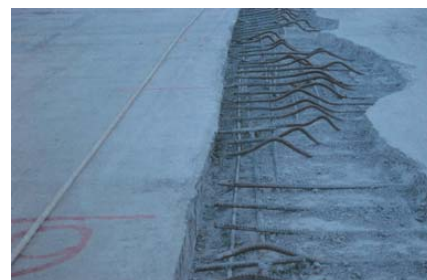

Figure 10 - Tianshengqiao 1 : horizontal reinforcement bending along vertical joint (slabs L3 & L4)

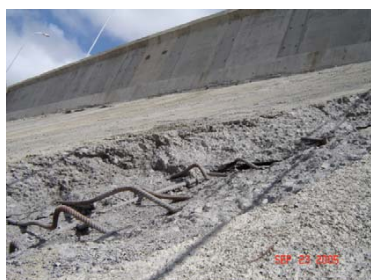

Figure 11 - Barra Grande (Sept. 2005)



Figure 12 - Campos Novos (Oct. 2005)



Figure 13 - Mohale (March 2006)

Case History

Concepts on CFRDs Leakage Control - Cases and Current Experiences (continued)

In TSQ.1, concrete spalling at face slabs were caused by concentrated stress along vertical joints slabs L3 and L4. A maximum horizontal strain recorded was -912μ (in strain gage SGH20) (where minus means compression) in June 2003 (Keming and al. 2007) just before rupture and spalling (Figures 9 and 10). This monitored strain corresponds to a failure compressive rupture ≈ 22 MPa ($E_{conc} = 24.000$ MPa). In Mohale, during concrete spalling along vertical joint L 17/ L18, horizontal strains ranging from -600 to -620μ have been recorded, which means a failure compressive rupture ≈ 20 MPa (Palmi, Tohlang, 2007). The usual specified concrete is a pozzolanic cement with strength between 20 and 25 MPa at 28 days, (sometimes this strength is specified for 60 or 90 days). Therefore, Mohale and TSQ.1 slabs should not have collapsed probably by horizontal compressive strain only, but due to the bending stresses. Horizontal reinforcement bending (Figures 10 and 13) confirmed this hypothesis. Barra Grande (Figure 11) and Campos Novos with a similar spilling phenomenon (Figure 12) must be followed the same behavior.

Barra Grande, Campos Novos and Mohale CFRDs, have in common low construction modulus of deformability (40 – 70 MPa) and relatively narrow valley (Valley Shape Factor of **3.0**, **2.6** and **3.6** respectively). (Pinto N.,2007). Tianshengqiao 1 has also low construction modulus of deformability, ranged 30 – 48 MPa. (Wu, Freitas and al., 1999), but a high Valley Shape Factor (5.7).

Despite the necessity of having a high rockfill modulus of deformability (> 90 MPa), in order to avoid high deformations, narrow Valley Factor deep influence in rockfill performance and slab deformations are not clearly explained, so far, in this author view. Reservoir water level pressure induces rockfill deformations from center areas toward dam top and consequently slab high deflections along all these areas. Since CFRDs spalling issues (2003 – 2006), center vertical joints have been designed with a flexible filler material between slabs, consisting of wood or PVC or similar materials, to mitigate compression stresses (Materón, 2008). This “compressive fill concept” along the vertical joint was applied during the repairing works at Barra Grande and Campos Novos. Currently has been adopted in several tall CFRDs, such as: Shibuya, El Cajón, Kárahnjúkar (Figure 14), Bakun and Mazar.

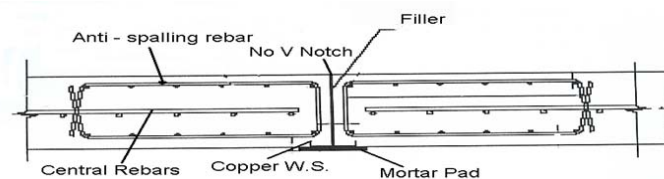

Figure 14 Kárahnjúkar face slab at central compression zone, modified design (Perez, Johannesson & Stefansson, 2007).

Slabs current experiences show a tendency to generate high stresses close to abutments. Therefore, the use of 0.5% reinforcing in area of 25-30m perpendicular to the plinth alignment has been recommended. Also in high dams located in narrow valleys anti-spalling compression rebars have been located in two layers increasing the percentage to 0.5% as protection against high compression stresses. For current CFRDs, the following design criteria are being adopted along vertical joint: i) keep the slab design thickness by imbedding the mortar pad into the curb extruded concrete; ii) use flexible filler along vertical joint (wood, neoprene, etc); iii) reduce (maximum 2 mm) or eliminate the upper V notch; iv) anti-spalling reinforcement. In addition, for narrow valleys (Shape Factor $A/H^2 \leq 3.0$), additional vertical joints (7.5 m slab wide) must be considered at abutments areas to mitigate stresses, as adopted at Shuibuya, Bakun and Mazar CFRDs.

4.4 Expansion joints: are placed as a connection between the slab upper part and the parapet wall crest wall. Although localized some meters above the Normal Water Level operation, the expansion joint design is a key point for a good slab leakage control. A copper waterstop is often used in this expansion joint.

5. Final Comments

Mathematical models and numerical FEM analysis are interesting designing tools to estimate the deformation pattern and slab bending movements of the embankment deformations during construction and impounding, and in the long run (dam operation) due to the rock fill creep effect. However, empirical design and construction details from experience and observation of CFRDs performance still prevails, significantly, so far.

Tall CFRDs structures ranging between 250 and 300m are being currently in feasibility studies. Therefore, basic criteria design proposed by Cooke and Sherard in 1987, are under review. A better estimation of the rockfill and concrete face displacements and inter face stresses of rockfill, extruding curb and concrete slab must be deeply concerned in mammoth CFRDs structures taller than 300m, to avoid ruptures and high leakage issue. Central vertical (compression) joints current design concept, introducing wood, neoprene, flexible materials, has aiming to mitigate high compression and bending stresses and bending movements along vertical joints. Slab spalling ruptures recorded in Mohale and Tianshengqiao 1 CFRDs, cannot be explained as horizontal compression stress issues, only. Bending stresses seem to have caused bending of the rebars and concrete spalling as the main effect. Similar phenomenon occurred in Barra Grande and Campos Novos, in this author opinion.

Bond-breaker design concept, as asphalt emulsion or other materials, placed between the slabs and curb face have not clearly proved as a good solutions to mitigate interface friction in the contact curb x slab, in this author view.

The **spalling** mentioned accidents that occurred just confirm the inherent safety of the tall CFRDs dam type. A recent earthquake (2008) of 8.0 (Richter) magnitude occurred in Zipingpu CFRD (China, 160 m height), with the epicenter at 10 km from the dam, registered a horizontal acceleration of 2g at crest level. A settlement of 40 cm in the crest, some slabs damaged and an increase in the

Case History

Concepts on CFRDs Leakage Control - Cases and Current Experiences (continued)

leakage flow from 10 to 15 l/sec were the only consequences. The dam resisted quite well the earthquake, confirming inherent safety conditions (Zeping X., 2009).

6. References

1. Cooke, J.B.; Sherard, J.L.(1987) , “ Concrete Face Rockfill Dams: 1. Assessment;II. Design. Journal of Geotechnical Engineering, ASCE,v.113,1987.
2. Resende, F.; Materón, B., (2000) “ Itá Method – New Construction Technology for the Transition Zone of CFRDs. ICOLD, Beijing, China 2000.
3. Méndez F.; Marengo, H.M, (2008) , “ Extruded curb technology and a fast-track high CFRD” Key Technology for High CFRDs Construction – International Sympos., Hong Kong, China.
4. Cooke, J.B.,(1991), “ The Concrete-faced rockfill dam” – Water Power & Dam Construction – January 1991.
5. Pinto, N.L.S., Mori, R.T. (1988), “ A New Concept of a Perimetric Joint for Concrete Face Rockfill Dams” – Proceedings , 16th Congress of ICOLD , Q61, San Francisco, USA, 1988.
6. Guocheng, J., Keming, C. (2000), “ Concrete Face Rockfill Dams in China” - Proceedings of International Symposium on High Earth-Rockfill Dams, Vol. I –Oct. 1993, Beijing, China.
7. Cruz, P., Bayardo ,M., Freitas, M.S., (2009) “ Concrete Face Rockfill Dams” , Oficina de Textos, Editor, 2009.
8. Cruz, P., Bayardo ,M., Freitas, M.S., (2008) “ Design Criteria for CFRDs “, Key Technology for High CFRDs Construction – International Symposium , Hong Kong, China.
9. Pinto, N.J. de S. (2007) , “ The Design and Construction of Extra High CFRDs, Third International Symposium on CFRDs, Florianopolis, SC, Brazil.
10. Keming, C, Zhongping and Caichang Guang (2007) , “ Design Research for very High CFRD” , Workshop on High Dam Know-How, May 22 -24, Yichang, China.
11. Johannesson, P., Tohlang, S., (2007), “ Updated Assessment of Mohale Dam Behavior, including of slab cracking and seepage evolution”, Third Symposium on CFRD –Dams, Oc. 2007, Florianopolis, SC, Brazil.
12. Wu, G., Freitas, M.S. and al. (1999), “ Tianshengqiao 1 CFRD- Monitoring of the Rockfill Dam displacements”, Proceedings of 99th International Conference on Dam Safety and Monitoring”, Three Gorges Project Site, 1999, China.
13. Materón, B. (2007) : “ State of Art of Compacted Concrete Face Rockfill Dams “(2007) , Workshop on High Dam Know-How, 2007, Yichang, China .
14. Perez, H.J.; Johannesson, P.;Stefansson, B., (2007) “ The Kárahnjúkar CFRD in Iceland Instrumentation and First Impoundment Dam Behavior”, Third International Symposium on CFRDs, Florianopolis, SC, Brazil.
15. Zeping Xu, (2009) , “ Performance of Zipingpu CFRD during the Wenchuan earthquake”, Hydropower & Dams, Issue three, 2009.

TC Activity

TC34 - Workshop at 17th ICSMGE

On the occasion of 17th ICSMGE, TC34 Workshop was held at Alexandria on October 3, 2009, from 16:00 to 18:00. The meeting in open style was successively organized with two presentations and discussion listed below:

- Presentations

- 1) "On the Second order work instability -Relation to the stability in the sense of Lyapunov", F. Oka (Kyoto University)
- 2) "Strain field measurement using X-ray CT data", J. Otani (Kumamoto University)

Prof. Oka talked about the relation between the stability condition based on the second order work and the stability of Lyapunov, while referring to localization and bifurcation of soils. Prof. Otani delivered a presentation on the quantitative evaluation of deformation/strain field observed by the X-Ray CT technique by comparing measured strain through the PTV and PIV.

- Discussion

"Final report of TC34 (2005-2009)" and "Future activity of TC34", F. Oka (Kyoto University, TC chair)

After the Workshop, printed final report was distributed among the participants. Following contents can be downloaded from the TC34 website: <http://nakisuna2.kuciv.kyoto-u.ac.jp/tc34/>

- CONTENTS:

- 1) Final report of TC34 (2005-2009)
- 2) State-of-the-art report:
 - P. Lade: Effect of Grain Crushing on Behavior of Granular Materials
 - F. Oka: On the explanation of Hill's stability conditions for elasto-plastic materials -Relationship between the stability criterion by the second order work and Lyapunov's stability condition-
 - I. Vardoulakis and E. Veveakis: Thermo-hydro- mechanical instability during rapid shearing of Geomaterials
 - R. Wan: Instabilities in Geomaterials - Localized and Diffuse Failure



Professor F. Oka (above) and Professor J. Otani (below) during the presentation

Planned Activity for 2009-2013

Following activities were discussed and planned for next term.

- ★ Next chair and members
- ★ New R&D area
- ★ *Short courses for training and education of advanced prediction and simulation methods in geotechnical engineering, 2006-2009; venue and the date are not decided.
- ★ Int. Workshop and Symposium, etc.

TC Activity

TC-28 - Survey on design practice in the field of soft ground tunnelling

Technical Committee TC 28 has a major commitment towards consolidating and sharing technical knowledge and experience in ground investigation, design, analysis and construction of underground works in the urban environment, including tunnels, caverns and deep excavations.

Besides its main activity of organising an international conference every three years and regional workshops, two new initiatives have recently been launched by TC28. The first concerns the creation of a database relating to tunnelling and deep excavation works and the second the preparation of guidelines for comparing field or physical model observations with numerical simulations.

Additionally, during our 2008 International Symposium held in Shanghai, TC28 members decided that, instead of producing national reports, which often result in tedious repetitions, it would be more interesting to launch a survey, in the form of a questionnaire, on design practice in the field of soft ground tunnelling, based on examples of national surveys previously carried out in Japan (K. Fujita) and in Brazil (A. Negro).

General objectives of the survey

Currently there are internationally many huge developments involving tunnelling projects in soft / weak ground. These are often in the urban environment where there are usually many complications because of the need to protect existing infrastructure and sensitive buildings. The objective of the questionnaire is to assimilate, at an international level, the different practices adopted for the conception, design and analysis of these tunnels and other associated matters such as the protection of buildings.

The results from the various aspects considered in the survey are to be analysed by several specialists from TC28, who will form a dedicated working group. This group will provide a synthesis of the findings that will be presented during the next, sixth TC28 International Symposium which is to be held in Rome in 2011. This synthesis will be sent in advance to all those who responded to and provided information for the survey. It should allow all those involved in the field of urban tunnelling (from the geotechnical perspective) to consider their approaches in relation to those currently adopted and used by others working in different environments. They will then be able to reflect on the various elements covered by the survey and to consider where and how to make improvements.

Format of the questionnaire

The questionnaire that has been sent out is largely based on a similar survey instigated in Brazil by A. Negro (2009), the results from which were presented in a paper included in the proceedings of the fifth TC28 International Symposium held in Shanghai in 2008.

The intention is that the survey exclusively concerns tunnels:

- constructed in soft soils, cemented soils and weak rocks, and excludes tunnels driven in rock;
- with a diameter equal or greater than 1.5m (which excludes microtunnels), regardless of their use;
- bored either using a staged method (sometimes referred to as NATM or Sprayed Concrete Lining), or by tunnel boring machine (TBM), or by jacking the lining pipes behind the TBM (excluding linings installed by directional drilling).

The main points addressed by the questionnaire are the following.

- 1 - General description of the projects.
- 2 - Sequentially excavated tunnels (construction method, face stability, lining...).
- 3 - Driven tunnels (TBM type, face stability, TBM parameters monitoring...).
- 4 - Settlements and damage.
- 5 - Numerical approaches.
- 6 - Field monitoring.
- 7 - Research, innovation and improvements.

Organisation and processing of the survey data

The questionnaire has been sent to all the TC28 members for distribution at a national level to experienced engineers who supervise or are involved with the conception and design of tunnels. The intention is to collect information from various sources such as consulting engineers, contractors, tunnel owners and local authorities. During the TC28 meeting held at the 2009 ICSMGE in Alexandria, Dr Arsenio Negro agreed to coordinate the working group that will analyse the various aspects considered in the survey.

TC Activity

TC28 - Survey on design practice in the field of soft ground tunneling (continued)

Progress of the survey and first answers

The first dissemination of the questionnaire to all TC28 members was in April 2009. Since then there has been a steady, sometimes sporadic, stream of replies, a couple of reminders have been sent and completed questionnaires are still coming in. As the survey is still underway it is not appropriate to present any detailed results at this time. However, one can note the following statistics from the first wave of replies.

- A total of 37 replies to the survey have been received to date, coming from 10 different countries, with frequencies ranging from 1 to 7 answers per country.
- With regard to the activities of the companies or people that have answered, they are distributed in the following way: academic (3), consultants (22), contractor (6), regulator (5), and specialist (7).
- The three tables below give an initial idea of the statistics concerning the tunnel types, range of diameters and soil types encountered in projects handled by the respondents to the survey. It may be noted that road, rail and subway tunnels represent nearly 80% of all the projects, and that for more than 80% of them their diameter is greater than 6m and for nearly 60% greater than 10m.

Purpose of the tunnels	number
water supply	10
sewage networks	30
drainage pipes	6
electrical or similar networks	3
pedestrian tunnels	19
Road tunnels	100
railway tunnels	93
subway tunnels	78
underground hydroelectric facilities	8
other purposes *	1

Diameter of the tunnels	number
between 1.5 and 3.0 m	28
between 3.0 and 6.0 m	29
between 6.0 and 10.0 m	97
greater than 10.0 m	199

Ground types encountered	number
cohesive soil	49
soils with small cohesion	41
soils without cohesion (i.e. granular)	40
mixed conditions on the face of the tunnel	73
hard soils/soft rocks	113
other types*	24

Clearly an excellent start and response to the survey has been made. The survey will be re-launched to encourage those who have not yet completed it and also to widen the geographical distribution of the answers.

We kindly request that if you have found this brief article interesting and are able and willing to complete the survey yourself we would be very grateful to receive your response.

The questionnaire (paper or electronic version) can be downloaded with the following addresses:

Paper version <http://dl.free.fr/uDTLeDW9U>

Electronic version <http://dl.free.fr/rvAAHPifZ>

For any other information, please do not hesitate to contact R. Kastner (Richard.kastner@insa-lyon.fr), J. Standing (j.standing@imperial.ac.uk) or A. Negro (bureau@bureauprojetos.com.br)

Référence

Negro A., 2009. Urban tunnels in soil: Review of current design practice in Brazil, Geotechnical Aspects of Underground Construction in Soft Ground, Shanghai, China - Ng, Huang & Liu (eds) Taylor & Francis.

Reported by R. Kastner, J. Standing and A. Negro

News



The 4th International Young Geotechnical Engineers Conference (4iYGEC) was held at the Hotel El Mahrousa on the sea front in Alexandria on the 3 and 4 October 2009. The organizing committee was chaired by Prof. Fatma Baligh. The event gathered 89 papers, and 83 of the authors – representing 42 countries on five continents - travelled to Alexandria to present their papers. Eleven participants came from Africa, 7 from the Americas, 21 from Asia, 2 from Australia and 42 from Europe. The conference began with an opening ceremony where Prof. Fatma Baligh, Prof. Mamdouh Hamza, Prof. Neil Taylor and Prof. Pedro Seco e Pinto welcomed the participants.

Following the opening ceremony, a plenary lecture presented by Prof. Ahmed Elgamal (University of California, San Diego, USA) preceded the technical sessions that addressed these themes:

- Soil Behaviour and Properties, New Concepts and Correlations
- Ground Improvement: Chemical, Mechanical and Reinforcement
- Seepage Flow, Contaminated Soil Treatment and Response
- Landslide and Slope Stability, Case Studies
- Deep Foundation Design and Practice
- Performance of Different Types of Earth Retaining Structures
- Soil Structure Interaction, Risk Management
- Underground Construction

At the end of each session, a symbolic prize was awarded for the best presentation.

As the 4iYGEC is held within the framework of the 17th International Conference on Soil Mechanics and Geotechnical Engineering (17th ICSMGE), all of the young participants of 4iYGEC were invited to attend the 17th ICSMGE held in the Library of Alexandria (Bibliotheca Alexandrina). During the two first days of the 17th ICSMGE (5-6 October 2009) the participants attended five State-of-The-Art lectures, a Heritage Lecture and two lectures on Great Projects. On 6 October in the session "Thoughts and Observations," the 4iYGEC conference chairperson and three chosen participants presented a briefing of what had taken place at the 4iYGEC. An optional Technical Visit to the San-Stefano Hotel Harbour was also scheduled this day.

A Cultural Evening of Egyptian Folk Dancing was held around the swimming pool at El-Mahrousa Hotel where traditional oriental food and beverages were served to the 4iYGEC participants.

The 4iYGEC was a great contribution to the sharing of scientific knowledge in the field of soil mechanics and geotechnical engineering.



Delegates and organizing committee of the 4th International Young Geotechnical Engineering Conference.

Reported by Prof. Fatma Baligh

News

Summary of the 4th International Young Geotechnical Engineering Conference – A Collective View of Geotechnical Engineering Through the Eyes of Young Geotechnical Engineers

The International Young Geotechnical Engineering Conference aims to bring together young students, professors, and practitioners to report on and discuss the current state of geotechnical engineering. This conference is aligned with the International Conference on Soil Mechanics and Geotechnical Engineering, such that young engineers can participate with the global geotechnical community and become active members in the International Society of Soil Mechanics and Geotechnical Engineering (ISSMGE).

Reverberating through the eight technical sessions were state-of-the-art laboratory techniques, increased focus on soil-structure interactions, and use of numerical models to solve geotechnical problems. The ubiquitous use of numerical models in research and practice exhibits the current interest and capabilities of the young geotechnical engineer. Overall, the conference succeeded in bringing together young engineers from around world and creating a comfortable atmosphere to foster exchange of technology, ideas, research methodologies, and culture. The 4iYGEC, and all young engineering conferences, provide a unique platform that promotes networking and collaboration to advance professional and personal relationships.

Delegates of the 4iYGEC were asked by the ISSMGE to prepare a presentation for the 17th International Conference on Soil Mechanics and Geotechnical Engineering (XVII ICSMGE). The presentation was to provide a synopsis of the current state-of-practice of young geotechnical engineering, the collective vision of the young engineers, and recommendations for the progression of the ISSMGE. The following summarizes that presentation and the views of the young delegates.

The delegates of the 4iYGEC see a number of problems facing the geotechnical engineering community in the future. First and foremost are geotechnical problems arising from the increasing global population. The current population growth rate is forcing engineers to increasingly work in poor soil areas, with many of these areas stricken by geological and environmental hazards. Solving or mitigating these problems is further complicated by the desire for sustainable solutions. While young engineers fully support sustainable engineering solutions to geotechnical problems, some of the fundamental engineering judgment required to solve these problems is perhaps being lost. The delegates believe that current geotechnical education needs an increased focus on engineering fundamentals and soil behavior. Students will benefit from understanding the problem-solving progression of real-world projects, i.e., site assessment → data collection → data analysis → report writing and recommendations. While young engineers embrace and acknowledge the benefits of modern technology in geotechnical engineering, a healthy balance between engineering fundamentals and computing capabilities will aid in developing sustainable solutions to the most difficult geotechnical problems of the future.



Delegates and organizing committee of the 4th International Young Geotechnical Engineering Conference.

A major theme of the XVII ICSMGE was bridging the gap between academia and industry. Nowhere is this gap more prevalent than in undergraduate engineering education. Hands-on experience through internships, work co-ops, field trips, volunteer efforts, and other ways to get young engineers involved in real-world problems will enhance engineering education. Many young engineers already participate in these outreach activities; however, university curricula would benefit from requiring students to engage in some form of practice prior to graduating. These experiences will advance a student's comprehension of engineering application, and perhaps act as a stepping-stone for their transition from academia to industry.

News

Summary of the 4th International Young Geotechnical Engineering Conference – A Collective View of Geotechnical Engineering Through the Eyes of Young Geotechnical Engineers (continued)

The gap between academia and industry, and the gap between junior and senior level engineers, can be narrowed by promoting the involvement of young engineers in the ISSMGE. For example, technical committees should reach out to incorporate young engineers in order to transfer knowledge and gain diverse perspectives. Enhancing the ISSMGE website by incorporating connection portals for participating ISSMGE members, young geotechnical engineering newsletters, and archives for masters and doctoral theses will also aid in drawing the attention of more young engineers. Lastly, the ISSMGE would benefit from increasing global collaborations that bring engineers together to work on geotechnical problems. While conferences provide an important service in global networking, they are often limited to short discussions on research and practice. Making grants available for students and young engineers interested in global collaborative research and education will further stimulate global networking. Young engineers from all over the world should feel welcome and safe to collaborate on geotechnical problems in any nation.

During the XVII ICSMGE a common request heard throughout the state-of-the-art lectures was the need for more detailed site characterizations and case studies, a sentiment echoed by the 4iYGEC delegates. By promoting the availability of data on well characterized soil sites and case studies (e.g., International Journal of Geoengineering Case Histories and Characterization and Engineering Properties of Natural Soils), young researchers who do not otherwise have the ability to gather their own data, can supplement their modeling efforts with trial-and-error test runs on sites and studies familiar to the geotechnical community.

The 4iYGEC was a unique and beneficial opportunity for all participating delegates. The visions and requests presented herein are largely in accordance with the manifesto prepared by delegates of the 3iYGEC in Osaka, Japan. While the 4iYGEC delegates recognize that some of the aforementioned points are currently available or in progress through the ISSMGE, the general consensus amongst all delegates was that unless engaged in a setting such as the iYGEC few young engineers are aware of the ongoing efforts by the ISSMGE. In closing, delegates of the 4iYGEC would like to emphasize two points that overlap with the visions of newly elected ISSMGE President Jean-Louis Briaud of Texas A&M University. First, the idea of stimulating academic and practice collaboration through publishing case studies in The International Journal of Geoengineering Case Histories. Young professors and graduate students eager to publish can network with practitioners who have large compilations of available data. Secondly, creating an ISSMGE student board would help bridge the gap between the active ISSMGE members and future members. The student board would also promote the ISSMGE in young engineering communities, stimulating students' interest and their desire to join.

Reported by Christopher A. Bareither¹ and J. Suzanne Powell²

¹ Graduate Research Assistant, Geological Engineering, University of Wisconsin, Madison, WI 53706, USA, bareither@wisc.edu

² PhD Candidate, Geological Sciences & Geological Engineering, Queen's University, Kingston, ON. powell@geoladm.geol.queensu.ca

News

XVII International Conference on Soil Mechanics and Geotechnical Engineering – Alexandria, Egypt 5-9 October 2009 The Academia and Practice in Geotechnical Engineering

The 17th International Conference on Soil Mechanics and Geotechnical Engineering was held in the lovely city of Alexandria on the beautiful Mediterranean Sea coast from 5 through 9 October 2009. Alexandria, which was built for Alexander the Great in 332-331 BC, is a culturally diverse city of ancient and modern attractions with a European influence. The city extends about 32 km along the north central coast of Egypt and is 220 km from Cairo. Around 80 percent of all of Egypt's imports and exports pass through the Alexandria port.

The 17th ICSMGE was held at the Bibliotheca Alexandrina. Constructed with the largest diaphragm wall circle in the world, the Bibliotheca Alexandrina is a revival of the ancient Great Library of Alexandria (built in 288 BC and operating until 412 AD), which established the city as the greatest scientific and intellectual center in the world at the time.

ICSMGE OPENING CEREMONY

The 17th ICSMGE was opened with an address from Prof. Mamdouh Hamza, the chairman of the conference. Prof. Pedro Sêco e Pinto, president of the ISSMGE, then welcomed the delegates on behalf of the International Society of Soil Mechanics and Geotechnical Engineering, and Eng. Ahmed El Magraby, Egypt's Minister of Housing, Utilities and Urban Development, extended an official welcome to Egypt to the conference participants. Mr. Adel Labib, the Governor of Alexandria, and a representative of Egypt's Minister of Irrigation and Water Resources added their enthusiastic support to the conference and also extended their good wishes to the delegates in Alexandria.

PARTICIPATION

The conference attracted 1341 geotechnical and ground engineering academics and practitioners from 86 countries, with the largest number of participants (108) hailing from Japan. Africa was also well represented with 144 participants from 16 countries across the continent. Eighty-one participants from Egypt, the host country, joined their international colleagues in Alexandria.

17th ICSMGE Attendance	
Number of Countries	86
Largest Participation from Japan	108
Participation from AFRICA (16 countries)	144
Participation from Host country	81
No. of participants	983
No. of Students	75
Exhibitor Personal	82
Accompanying persons	201
Total Number of Participants	1341



Council Meeting at 17th ICSMGE



Prof. Briaud and Prof. Sêco e Pinto

News

XVII International Conference on Soil Mechanics and Geotechnical Engineering – Alexandria, Egypt 5-9 October 2009 The Academia and Practice in Geotechnical Engineering (continued)

Country Breakdown of 17th ICSMGE Delegates

	Country	Participants		Country	Participants		Country	Participants
1	Albania	7	29	Ghana	1	57	Pakistan	2
2	Algeria	4	30	Greece	21	58	Panama	1
3	Argentina	7	31	Hong Kong	12	59	Peru	1
4	Australia	35	32	Hungary	4	60	Poland	12
5	Austria	6	33	India	16	61	Portugal	16
6	Bangladesh	2	34	Indonesia	3	62	Qatar	1
7	Belgium	11	35	Iran	15	63	Romania	8
8	Brazil	33	36	Iraq	3	64	Russian Federation	28
9	Bulgaria	3	37	Ireland	3	65	Senegal	2
10	Cameroon	4	38	Italy	34	66	Serbia	1
11	Canada	25	39	Japan	108	67	Singapore	5
12	Chile	6	40	Jordan	4	68	Slovakia (Slovak Repu	2
13	China	67	41	Kazakhstan	4	69	Slovenia	6
14	Colombia	5	42	Korea, Republic Of	32	70	South Africa	9
15	Congo	2	43	Latvia	1	71	Spain	17
16	Costa Rica	7	44	Lebanon	5	72	Sri Lanka	1
17	Croatia	10	45	Libyan Arab Jamahiriya	9	73	Sudan	4
18	Czech Republic	7	46	Lithuania	1	74	Sweden	6
19	Denmark	4	47	Macedonia	3	75	Switzerland	8
20	Dominican Republic	1	48	Malaysia	11	76	Taiwan	13
21	Ecuador	1	49	Mexico	16	77	Thailand	7
22	Egypt	81	50	Morocco	3	78	Tunisia	6
23	Estonia	3	51	Mozambique	2	79	Turkey	10
24	Ethiopia	2	52	Netherlands	27	80	Ukraine	7
25	Finland	10	53	New Zealand	10	81	United Arab Emirates	10
26	France	46	54	Nigeria	13	82	United Kingdom	17
27	Georgia	1	55	Norway	11	83	United States	57
28	Germany	35	56	Oman	1	84	Venezuela	1
						85	Chad	1
						86	Ivory Cost	1

SCIENTIFIC PROGRAM

The conference organizing committee received 803 abstracts from authors wishing to present their ideas and experiences at the conference. Of these, 688 papers representing 69 member societies were selected for presentation.

Five excellent State-of-the-Art Lectures were presented during the first two days of the conference. On the opening day, Prof. Paul Mayne gave a lecture on the topic Material Behaviour and Testing and Dr. Brian Simpson presented a lecture covering Analysis and Design. Dr. Arsenio Negro opened Day Two of the conference with his lecture on Prediction, Monitoring and Performance. Professors Chu Jian and Mark Jakska then followed with their lectures addressing the topics of Construction Processes and Management, Training and Education, respectively. A spectacular Heritage Lecture was also delivered on Day Two by Dr. Zahi Hawass, Director of Egypt's Supreme Council of Antiquities.

Delegates also enjoyed two distinguished Great Project lectures presented on Day Two: Prof. Michele Jamiolkowski discussed the site characterization and geotechnical problems faced in safeguarding Venice from high tides and Mr. Wolfgang Brunner described the development of foundation construction techniques during the past 5,000 years. The Practitioners/Academia Forum, led by Prof. William Van Impe and Prof. Mamdouh Hamza on the opening day, enabled participants to explore and debate the collaborative efforts required to achieve geotechnical and construction successes.

News

**XVII International Conference on Soil Mechanics and Geotechnical
Engineering – Alexandria, Egypt
5-9 October 2009
The Academia and Practice in Geotechnical Engineering
(continued)**

17th ICSMGE Program Statistics:

No. of State of the Art Lectures	5
No. of contributors to SOA Lectures	18
Heritage Lecture	1
Great Project Lectures	2
Academic-Practitioner Forum	1
No. of Technical Sessions	15
No. of General Reporters	16
No. of Panelists	45
No. of Short Presentations	180
Total No. of Speakers	260

SATELLITE CONFERENCES AND WORKSHOPS

Sixteen Satellite Conferences and Workshops were held before or during the conference. The list below shows the Technical Committees, Joint Technical Committees, and Regional Technical Committees that organized the events.

- TC 4 Earthquake Geotechnical Engineering
- JTC2 Representation of Geo-Engineering Data in Electronic
- TC 8 Frost Geotechnics
- TC 19 Joint Preservation of Historic Sites
- JTC 6 Ancient Monuments/Historical Sites
- TC 23 Limit State Design in Geotechnical Engineering
- TC 38 Soil Structure Interaction
- TC 34 Prediction & Simulation Methods in Geomechanics
- TC 2 Physical Modeling in Geotechnics
- TC 5 Environmental Geotechnics
- ATC 17 Solid Waste Management in Geo-environmental Engineering
- TC 6 Unsaturated Soils
- TC 17 Ground Improvement
- TC 28 Underground Construction in Soft Ground
- TC 29 Laboratory Stress Strain Strength Testing of Geomaterials
- JC 7 Joint Technical Committee on Soft Rocks & Endurated Soils
- JTC 3 Education & Training

FOURTH INTERNATIONAL YOUNG GEOTECHNICAL ENGINEERS CONFERENCE (4iYGEC)

The 4iYGEC began in Alexandria at the El Mahrousa Hotel two days before the main conference. The 4iYGEC participants then attended the State-of-the-Art and Special Lectures on the first two days of the ICSMGE. On 6 October, Prof. Fatma Baligh, the chairperson for the 4iYGEC, along with three selected 4iYGEC participants presented a briefing on the events of the young engineers' conference to the 17th ICSMGE participants.

SOCIAL EVENTS

Following the first day of the ICSMGE program, a Welcome Reception was held for all conference participants and their accompanying persons at the Qaitbay Citadel. The conference's Gala Dinner was held the next night in the Tea Garden of Salamlek Palace in Montazah, once the summer residence of King Farouk, Egypt's former ruler. The gala dinner was attended by around 700 people.

News

XVII International Conference on Soils Mechanics and Geotechnical Engineering – Alexandria, Egypt 5-9 October 2009 The Academia and Practice in Geotechnical Engineering (continued)

An Egyptian Cultural Evening was held at Antoniadis Gardens in central Alexandria on the evening of 8 October, where attendees, who included most conference participants and their accompanying persons, were able to experience the sights, sounds, and tastes of Egypt.

PROGRAM FOR ACCOMPANYING PERSONS

Persons accompanying conference registrants to Alexandria were able to participate in various organized tours in and around Alexandria, as well as attend the evening social events. The tours were quite popular, as represented by the number of participants:

Alexandria National Museum and Qaitbay Citadel	65
Roman Amphitheatre, Catacombs, and Pompey's Pillar	52
Bibliotheca Alexandrina	44
Underwater City of Cleopatra	3
Excursion to Rosetta (Rashid)	34
Excursion to Al Alamein	23
Over-day visit to Cairo	38

TECHNICAL VISITS

Five visits to geotechnically interesting sites were organized for interested conference participants on 9 October. The following table shows the number of people who participated in the visits:

Alexandria Port	242
East Port Said Port	21
Cairo Metro	26
Giza Pyramids Archeology	297
Aswan Dams	8

TECHNICAL EXHIBITION

Forty-three companies participated in the technical exhibition held in parallel to the 17th ICSMGE. The companies included developers and manufacturers of software, instruments and equipment, geosynthetics, geotextiles, contractors, consultants, and technical book publishers.

Software	8
Instrumentation and Geotechnical Testing Equipments	18
Contractors	7
Geosynthetics and Geotextiles	4
Consultants	4
Publishers	2
Total	43

The conference in Alexandria brought together academics and practitioners from around the globe who share an interest in geotechnical engineering and working together to develop innovative ideas that will contribute to the future successes in our profession and the built environment in which we all live.

Reported by Dr. Marawan Shahien

News**International Symposium on Geoenvironmental Engineering (ISGE 2009)
Zhejiang University, Hangzhou, China**

The International Symposium on Geoenvironmental Engineering (ISGE 2009) was successfully held in Zhejiang University, Hangzhou, China, from 8th Sep to 10th Sep, 2009. ISGE 2009 was organized by MOE Key Laboratory of Soft Soils and Geoenvironmental Engineering in Zhejiang University, CISMGE and CCIGS, under the auspices of ISSMGE TC5, sponsored by K.C.Wong Education Foundation, and National Natural Science Foundation of China, as well as Zhejiang University Zeng Guo-Xi Lecture Fund.

More than 200 academic researchers, practical engineers and administration officers from 21 countries and regions attended this symposium. Technical exchanges were carried out on 8 topics associated with "Reclamation of the Past and Toward a Sustainable Geoenvironment". 2 Zeng Guo-Xi Lectures, 26 Invited Lectures and 60 oral presentations were given by Prof. Pedro S. Pinto, Prof. R. Kerry Rowe, Prof. D.G. Fredlund, Prof. H.R.Thomas, Prof. Takeshi Katsumi and others. The proceeding of this symposium entitled with "Advances in Environmental Geotechnics" (943 pages) was published by Springer and Zhejiang University Press.



Reported by Prof. Xiao-wu Tang, Dept. of Civil Engineering, Zhejiang University. E-mail: tangxiaowu@zju.edu.cn

Announcement

Executive Director of the Integrated Research on Disaster Risk (IRDR) programme

The International Council for Science (ICSU), the International Social Science Council (ISSC) and the UN International Strategy for Disaster Reduction (ISDR) invite applications for the important post of Executive Director of the new Integrated Research on Disaster Risk (IRDR) programme.

The Executive Director will head an International Programme Office (IPO) for IRDR being established at the Center for Earth Observation and Digital Earth (CEODE) of the Chinese Academy of Sciences in Beijing, China, with core funding from the China Association for Science and Technology (CAST). The Executive Director of IRDR will be expected to:

- facilitate the development, implementation and co-ordination of IRDR science projects and joint projects with partner programmes;
- liaise with such international centres as may be established within IRDR;
- ensure effective representation and links between IRDR and other relevant research programmes and their sponsoring organisations, relevant entities of the United Nations system, as well as the international policy community and funding agencies;
- support the development and implementation of an information strategy which promotes networking within the disaster risk research community and the wider practice community;
- play a major role in organizing capacity building and outreach activities;
- promote the establishment and/or strengthening of national IRDR committees and regional initiatives; and
- promote IRDR internationally and assist in the acquisition of funding for the programme.

The Executive Director will hold a PhD in a natural, social, medical or engineering science discipline related to natural hazards and disaster risk reduction and have several years of direct experience of international research collaboration in an interdisciplinary setting. Applications should include: (i) a Curriculum Vitae; (ii) a letter outlining the skills and experience you feel you, the candidate, could bring to IRDR and its IPO; and (iii) the names and addresses of three individuals who have indicated their readiness to provide a reference. It is expected that the successful candidate would take up his/her appointment, located in Beijing, as soon as possible and no later than end-May 2010.

The address to which applications should be sent is:

Dr Howard Moore
International Council for Science (ICSU)
5, rue Auguste Vacquerie
75116 Paris
France
e-mail: howard.moore@icsu.org

The closing date for applications is 14 January 2010.

For more information on the IRDR see A Science Plan for Integrated Research on Disaster Risk – addressing the challenge of natural and human-induced environmental hazards which is posted on:

www.icsu.org/Gestion/img/ICSU_DOC_DOWNLOAD/2121_DD_FILE_Hazard_report.pdf

Announcement

International Conference on Geosynthetics – ICG 2010 Brazil



The 9th ICG Brazil – 2010 will provide an opportunity to learn about and discuss highly technical and scientific geosynthetics issues and their solutions. A primary objective of the conference is to present the most recent developments, improvements and new technologies from the international geosynthetics community.

IGS Brasil - Brazilian Association of Geosynthetics and ABMS - Brazilian Association of Soil Mechanics and Geotechnical Engineering will organize the Conference, under the auspices of the IGS, in association with the ISSMGE - International Society for Soil Mechanics and Geotechnical Engineering and with the support of the ABINT - Brazilian Association of Nonwoven and Technical Textiles.

Technical Program

300 papers were accepted and will be presented in 7 parallel sessions and displayed in 3 poster sessions, covering the following themes:

- Cases Histories
- Design approaches and numerical solutions
- Drainage and Filtration
- Geosynthetics in Agriculture and Aquaculture
- Geosynthetics in Dynamic Applications
- Geosynthetics in Environmental Applications
- Geosynthetics in Hydraulic Applications
- Geosynthetics in Mining Applications
- Geosynthetics in Road and Railway Applications
- Long-Term Performance and Durability
- New Geosynthetic Products
- Properties of Geosynthetics
- Reinforced Earthworks and access roads
- Reinforced walls and slopes
- Soil-Geosynthetic interaction

In addition, Special Lectures, 7 Training Lectures, 4 Short Courses and 4 Meeting the Industry will also be held.

The actual program is available at:

<http://www.9icg-brazil2010.info/ingles/programme.asp>

Exhibition

All booths are already sold for the commercial exhibition that will be held over 4 days during the conference, where associations and companies will display their products, services and technical solutions.

Venue

The scenery chosen for hosting the event is Guarujá, a beautiful coastal city, 86 km from the city of São Paulo. The natural beauty of its beaches and islands, perfect places for unforgettable tours, drives one of the Country's best-known leisure destinations.

The city of Guarujá has a large hotel chain, with several hotels located at the Enseada and Pernambuco beaches. This region will have a free shuttle service between the hotels and the event.

The Conference participants who choose not to stay at the hotel of the event, the SOFITEL JEQUITIMAR HOTEL, will easily find different accommodation options. The hotels listed on the website and those close to the shuttle stops will be interconnected with the Airport.

Announcement

International Conference on Geosynthetics – ICG 2010 Brazil (Continued)

Detailed information is available at the conference website:

<http://www.9icgbrazil2010.info/ingles/accommodation.asp>

Registration

Registration can only be completed through the conference website or at the office desk during the days of the event.

Detailed information is available at the conference website:

<http://www.9icgbrazil2010.info/ingles/registration.asp>

or by e-mail secretariat@9icg-brazil2010.info.br

Language

English is the official language of the conference.

Conference Secretariat

9ICG - Brazil 2010

Av. Brigadeiro Faria Lima, 1478 sala 314, São Paulo, SP, 01451-001, Brazil.

Tel.: + 55 11 3032 3399

Fax: + 55 11 3819 6311

E-mail: info@9icg-brazil2010.info

website: www.9icg-brazil2010.info

Editorial Remarks

The editorial board is pleased to send the ISSMGE members ISSMGE Bulletin Vol.3, Issue 4 in December 2009, which includes a message from the president, conferences, reminiscences, case history reports and TC activities. Contributions from member society is very much welcome. Any comments to improve the Bulletin are also welcomes. Please contact a member of editorial board or Vice-President for the region, or directly e-mail to Ikuo Towhata [towhata@geot.t.u-tokyo.ac.jp].

Event Diary

ISSMGE SPONSORED EVENTS - 2010

2nd International Symposium on CPT, CPT'10

Date: 9 - 11 May 2010
 Location: Hyatt Hotel & Resort, Huntington Beach, California, United States
 Language: English
 Organizer: TC 16 ISSMGE
 • Contact person: Dr Peter Robertson
 • Address: 2726 Walnut Avenue
 90755 Signal Hill – California- U. States
 • Phone: 562-427-6899
 • E-mail: probertson@greggdrilling.com
 Website: www.cpt10.com

17th Southeast Asian Geotechnical Conference

Date: 10-13 May 2010
 Location: Taipei Int'l Convention Center (TICC), Taipei, Taiwan
 Organizer: SEAGS, TGS
 • Contact person: Prof. Der-Wen Chang, Sec. Gen 17SEAGC
 • Address: Department of Civil Engineering,
 Tamkang University, Tamsui,
 Taiwan 25137
 • Phone: +886 (2) 2623-4224
 • Fax: +886 (2) 2620-9747
 • E-mail: dwchang@mail.tku.edu.tw
 Website: <http://www.17seagc.tw/welcome.htm>

9th International Conference on Geosynthetics

Date: 23 - 27 May 2010
 Location: Sofitel Jequitimar Hotel , Guarujá, Brazil
 Organizer: IGS, ABMS
 • Contact person: Secretaria do Congresso - (ICG - Brazil 2010)
 • Address: Av. Brigadeiro Faria Lima, 1478 sala 314,
 São Paulo, SP
 Brazil CEP 01451-001
 • Phone: 55 11 3032-3399
 • Fax: 55 11 3819-6311
 • E-mail: info@9icg-brazil2010.info
 Website: www.9icg-brazil2010.info

DECGE - 14th Danube-European Conference on Geotechnical Engineering

Date: 2 - 4 June 2010
 Location: University of Technology, Bratislava, Slovakia
 Organizer: Slovak group of ISSMGE
 • Contact person: GUARANT International spol. s r. o.
 • Address: Uhrova 10 - 831 01 Bratislava
 Slovak Republic
 • Phone: 421 2 54 430 206
 • Fax: 421 2 54 430 206
 • E-mail: decge2010@guarant.cz
 Website: www.decge2010.sk

NUMGE2010

Date: 2 - 4 June 2010
 Location: Trondheim, Norway
 Language: English
 Organizer: NTNU Trondheim
 • Contact person: Mrs. Astrid Bye
 • Address: NTNU Videre, Paviljong A, Dragvoll
 7491 Trondheim - Norway
 • Phone: 47 73 59 52 54
 • E-mail: numge2010@videre.ntnu.no
 Website: www.ntnu.no/numge2010

7th International Conference on Physical Modelling in Geotechnics ICPMG 2010

Date: 28 June - 1 July 2010
 Location: ETH Zurich, Honggerberg Campus , Zurich, Switzerland
 Language: English
 Organizer: ETH Zurich
 • Contact person: Laios Gabriela
 • Address: ETH Zurich, Institute for Geotechnical Engineering
 8093 Zurich - Switzerland
 • Phone: 41 44 6332525
 • Fax: 41 44 6331079
 • E-mail: info@icpmg2010.ch
 Website: www.icpmg2010.ch

International Symposium on Geomechanics and Geotechnics: From Micro to Macro

Date: 10 - 12 October 2010
 Location: Tongji University , Shanghai, China
 Organizer: Tongji University
 • Contact person: Prof. Mingjing Jiang
 • Address: Dept. of Geotechnical Engineering, Tongji University
 200092 Shanghai - China
 • Phone: 86-21-65980238
 • Fax: 86-21-65980238
 • E-mail: mingjing.jiang@tongji.edu.cn
 Website: geotec.tongji.edu.cn/is-shanghai2010/

6th International Congress on Environmental Geotechnics

Date: 8 - 12 November 2010
 Location: New Delhi, India
 Language: English
 Organizer: Indian Geotechnical Society
 • Contact person: Dr. G. V. Ramana
 • Address: Associate Professor, Department of Civil Engineering,
 Indian Institute of Technology Delhi, Hauz Khas
 110016 New Delhi - India
 • Phone: 911126591214
 • Fax: 911126581117
 • E-mail: 6icegdelhi@gmail.com
 Website: www.6iceg.org

Fifth International Conference on Scour and Erosion (ICSE-5) 8-10 November

Date: 8 - 10 November 2010
 Location: Holiday Inn Golden Gateway , San Francisco, California, United States
 Language: English
 Organizer: Geotechnical Institute of ASCE
 Secretary: • Contact person: Cathy Avila
 • Address: 712 Bancroft Road, Suite 333
 94598 Walnut Creek
 California
 United States of America
 • Phone: 1-925-673-0549
 • Fax: 1-925-673-0509
 • E-mail: cavila@avilaassociates.com
 Website: www.icse-5.org

Event Diary

ISSMGE SPONSORED EVENTS

(continued)

2011

The 3rd International Conference on Geotechnical Engineering for Disaster Mitigation and Rehabilitation 2011 (GEDMAR2011) combined with The 5th International Conference on Geotechnical and Highway Engineering

Date: 4 - 6 May 2011

Location: Semarang, Central Java, Indonesia

Language: English

Organizer: JWG-DMR, Diponegoro University

• Contact person: Ir. H. Wuryanto, MSc; Ir. Bagus Hario Setiaji, MT

• Address: Jl. Puri Anjasmoro Blok I.1 No.12

50144 Semarang

Central java

Indonesia

• Phone: 62-24-7622790

• Fax: 62-24-7622785

• E-mail: hpji_jateng@yahoo.com, geoconfina@yahoo.com

Website: reliability.geoengineer.org/GEDMAR2011/

7th International Symposium on Geotechnical Aspects of Underground Construction in Soft Ground Date: 16 - 18 May 2011

Location: Roma, Italy

Language: English

Organizer: TC28 and AGI

• Contact person: Dr. Ing. Claudio Soccodato

• Address: Associazione Geotecnica Italiana, viale dell'Università 11

00185 Roma

RM

Italy

• Phone: 39064465569

• Fax: 390644361035

• E-mail: info@tc28-roma.org

Website: www.tc28-roma.org

XIV Asian Regional Conference Soil Mechanics and Geotechnical Engineering

Date: 23 - 28 May 2011

Location: Hong Kong, China (

Organizer: HKGESM PolyU

Secretary: Conference Secretariat

• Address: Department of Civil & Structural Engineering

The Hong Kong Polytechnic University

Kowloon, Hong Kong

China (Hong Kong SAR)

• Phone: (852) 2766-6008

• Fax: (852) 2334-6389

XV African Regional Conference on Soil Mechanics and Geotechnical Engineering (13-16 June)

Date: 18 - 21 July 2011

Location: Maputo, Mozambique

Organizer: Soc. Moçambicana de Geotecnia

Fifth International Symposium on Deformation Characteristics of Geomaterials (IS-Seoul 2011)

Date: 31 August - 3 September 2011

Location: Seoul, Korea

Contact person: Prof. Dong-Soo Kim

• Address: Dept. of Civil & Environmental Eng.,

KAIST

305-701 Daejeon

Korea

• Phone: 82-42-350-3619

• Fax: 82-42-350-3610

• E-mail: dskim@kaist.ac.kr

XV European Conference on Soil Mechanics and Geotechnical Engineering

Date: 13 - 19 September 2011

Location: Athens Concert Hall , Athens, Greece

Organizer: HSSMGE

XIV Panamerican Conference on Soil Mechanics and Geotechnical Engineering (October) & V PanAmerican Conference on Learning and Teaching of Geotechnical Engineering, & 64th Canadian Geotechnical Conference

Date: 2 - 6 October 2011

Location: Sheraton Hotel Toronto, Ontario, Canada

Organizer: CGS

2012

11th Australia - New Zealand Conference on Geomechanics

Date: 15-18 July 2012

Location: Melbourne, Australia

(Please note that these dates still need to be confirmed.)

Event Diary

NON-ISSMGE SPONSORED EVENTS - 2010

Fifth International Conference on Recent Advances in Geotechnical Earthquake Engineering and Soil Dynamics

Date: 24 - 29 May 2010

Location: Marriott Mission Valley, San Diego, California, United States

- Contact person: Lindsay Bagnall
- Address: Distance and Continuing Education
Missouri University of Science and Technology
- Phone: 573-341-4442
- Fax: 573-341-4992
- E-mail: geoeqconf2010@mst.edu
- Website: 5geoeqconf2010.mst.edu

Geotechnical Challenges in Megacities

Date: 7 - 10 June 2010

Location: Moscow, Russia

Language: English, Russian

Organizer: NIIOSP & GRF

- Contact person: Mikhail Kholmyansky - Secretary General
- Address: 2-nd Institutskaya St., 6, build.12 NIIOSP
109428 Moscow
Russia
- Phone: 7 499 170 2709, 7 499 170 2767
- Fax: 7 499 170 2767
- E-mail: info@GeoMos2010.ru
- Website: www.GeoMos2010.ru/

The 11th Congress of the International Association for Engineering Geology and the Environment. (IAEG2010)

Date: 5 - 10 September 2010

Location: SkyCity Convention Centre, Auckland, New Zealand

Language: English

Organizer: Clare Wilton

- Contact person: The Conference Company
- Address: PO Box 90 040
1142 Auckland
New Zealand
- Phone: 64 9 360 1240
- Fax: 64 9 360 1242
- E-mail: iaeg2010@tcc.co.nz
- Website: www.iaeg2010.com

1st International Conference on Information Technology in Geo-Engineering (ICITG-Shanghai 2010)

Date: 16 - 17 September 2010

Location: Tongji University, Shanghai, China

- Contact person: Dr. Xiaojun Li
- Address: Secretary of ICITG-Shanghai 2010, Associate Professor,
School of Civil Engineering,
Tongji University,
No.1239 Siping Road
Shanghai 200092
China

- Phone: Ph: 86-21-65985174
- Fax: 86-21-69585140
- E-mail: lixiaojun@tongji.edu.cn
- Website: geotec.tongji.edu.cn/ICITG2010/default.html

2nd International Conference on Geotechnical Engineering - ICGE 2010 - Innovative Geotechnical Engineering

Date: 25 - 27 October 2010

Location: Hammamet, Tunisia

Language: English and French

- Contact person: Dr Imen Said
- Address: National Engineering School of Tunis
ENIT, BP 37,
Le Belvédère 1002
Tunis
Tunisia
- Phone: (216) 22 14 66 34
- Fax: (216) 71 87 14 76
- E-mail: imensaid2@gmail.com, essaieb.hamdi@enit.rnu.tn
- Website: www.enit.rnu.tn/fr/manifestations/icge2010/index.html

4th International Conference on Geotechnical Engineering and Soil Mechanics (2 - 3 November)

Date: 2 - 3 November 2010

Location: Power Institute of Technology, Tehran, Tehran, Iran

Language: English-Farsi

Organizer: Iranian Geotechnical Society

Secretary: • Contact person: Dr. Ali Noorzad

- Address: Power and Water University of Technology
East Vafadar Boulevard
4th Tehran Pars Street,
P.O.Box 16765-1719
Tehran
Iran
- Phone: 98-21-7393-2487
- Fax: 98-21-7700-6660
- E-mail: noorzad@pwut.ac.ir

2nd International Symposium on Frontiers in Offshore Geotechnics (ISFOG)

Date: 8 - 10 November 2010

Location: Perth, Western Australia, Australia

Organizer: COFS

Secretary: • E-mail: ISFOG2010@civil.uwa.edu.au

Website: www.cofs.uwa.edu.au/ISFOG2010/

FOR FURTHER DETAILS, PLEASE REFER TO THE ISSMGE WEBSITE - <http://addon.webforum.com/issmge/index.asp>

Corporate Members

 **acciona**
Infraestructuras turas AS
Avenida de Europa 18
Parque Empresarial La Moraleja
28108 ALCOBENDAS MADRID, SPAIN



Bauer Maschinen GmbH
Wittelsbacherstr. 5
86529 Schrobenhausen
GERMANY



Fugro N.V.
PO Box 41
2260 AA Leidschendam, NETHERLANDS



Deltares
PO Box 177
2600 AB Delft, NETHERLANDS



Georeconstruction Engineering Co
Izmaylovsky Prosp. 4., of. 414
Saint Petersburg, RUSSIA



Geo-Research Institute
Osaka Soil Test Laboratory
1-8-4, Otsubo-Honmachi
Nishi-ku, Osaka, JAPAN



Golder Associates Inc
1000, 940-6th Avenue S.W.
Calgary, Alberta
CANADA T2P 3T1



Jan de Nul N.V.
Tragel 60, B-9308 Hofstade-Aalst
BELGIUM



Kiso-Jiban Consultants Co., Ltd.
Nittetsu ND Tower 12 Fl.
1-5-7 Kameido, Koto-ku,
Tokyo, Japan 136-8577



NAUE GmbH Co KG
Gewerbestrasse 2
32339 Espelkamp-Fiestel
GERMANY



Norwegian Geotechnical Institute
P.O. Box 3930 Ullevaal Stadion
N-0806 OSLO
NORWAY

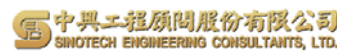

Sinotech Engineering Consultants, Inc.
171 Nanking E. Rd., Sec. 5, Taipei 105, TAIWAN,
REPUBLIC OF CHINA



SOLETANCHE BACHY SA
6 rue de Watford, 92000 NANTERRE BP511
FRANCE



S.N. Apageo S.A.S.
ZA de Gomberville
BP 35 - 78114 MAGNY LES HAMEAUX
FRANCE



Tensor International Ltd
Cunningham Court
Shadsworth Business Park
Blackburn, BB1 2QX, UK



Terre Armée

Sustainable Technology
Terre Armée
1 bis rue du Petit Clamart
Bâtiment C BP 135 78148 Velizy CEDEX
FRANCE



TRACTEBEL DEVELOPMENT ENGINEERING S.A.

Tractebel Development Engineering SA
Transportation Division
Geotechnology Section
7 Avenue Ariane B-1200, BRUSSELS
BELGIUM



Bentley Systems Inc
Corporate Headquarters
685 Stockton Drive, Exton, PA 19341
USA



Geoteknik SA
Dolapdere cad. 255, Şişli - İstanbul 80230
TURKEY



Engineering with Geosynthetics

Huesker Synthetic GmbH
Fabrikstrasse 13-15
48712 Gescher
Germany



Zetas Zemin Teknolojisi AS
Merkez Mah. Resadiye Cad. No. 69/A
Alemdag, Umraniye
İstanbul, 34794 TURKEY



Siemens Energy
Kaiserleistrasse 10
63067 Offenbach
GERMANY